

Between sky and ground

1. About the park of Vincennes

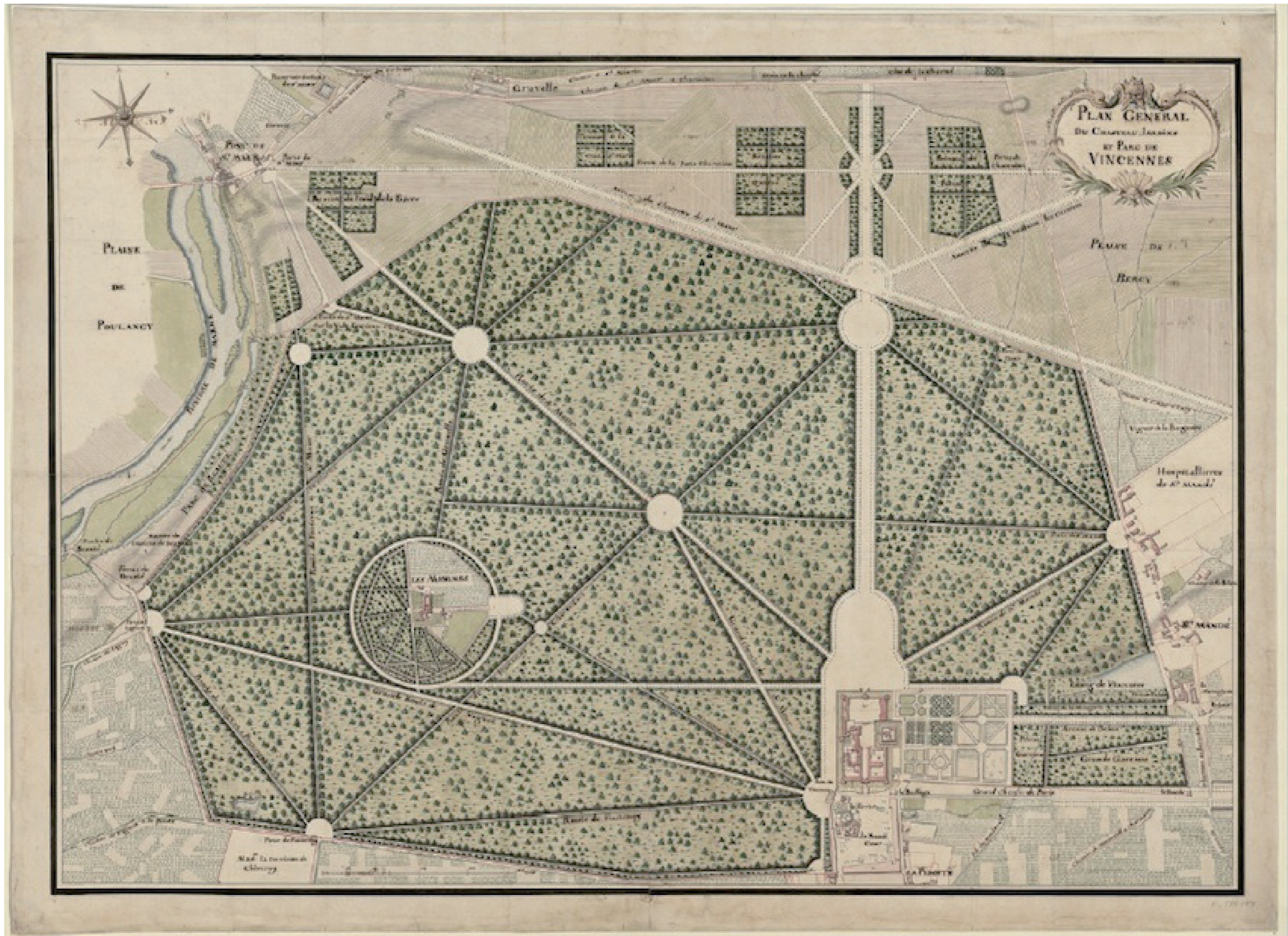

Source gallica.bnf.fr / Bibliothèque nationale de France

Planning park like "Paris"





Kemono-michi 獣道



2. Concept

Architecture

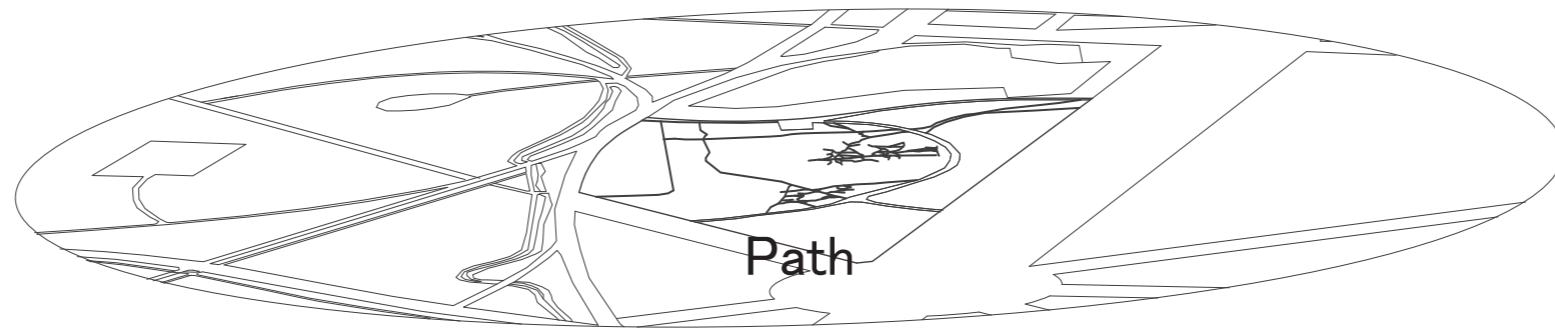

Site



3. Protocol

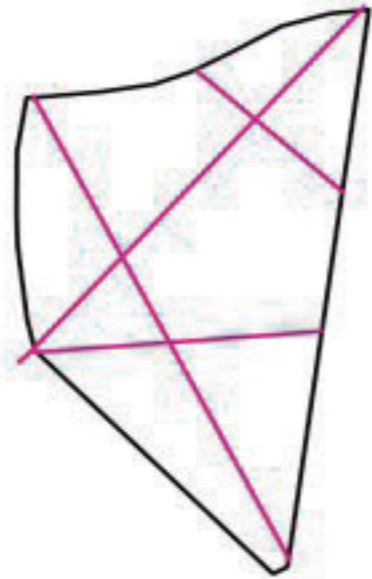

VOLUNTEER 1

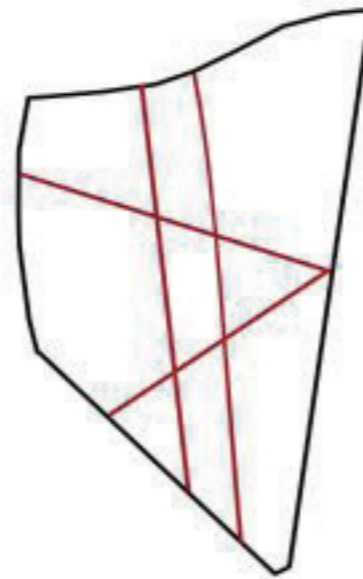

VOLUNTEER 2



VOLUNTEER 3

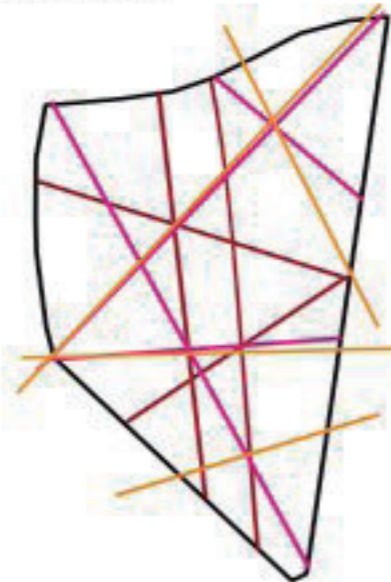

SUPERPOSITION

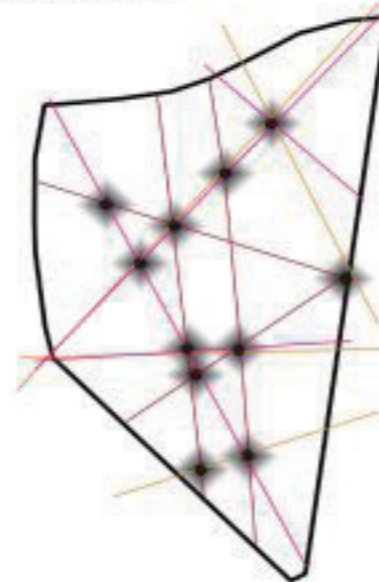

IDENTIFYING

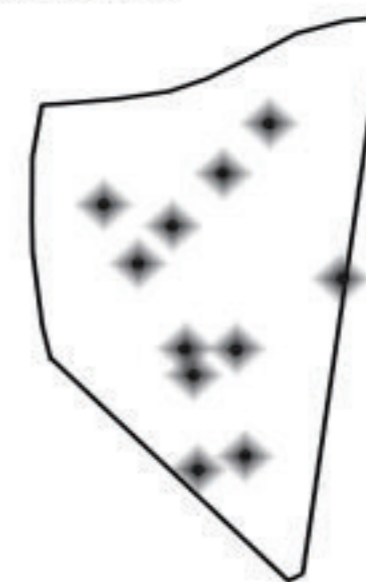

SYNTHESIS

Reference protocol – Between chance and Nature

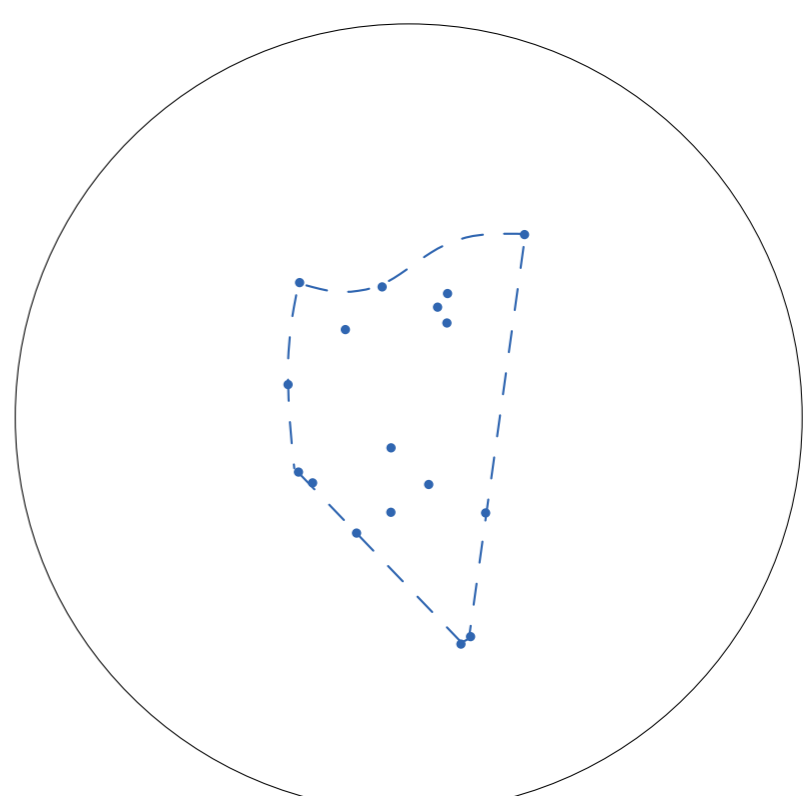
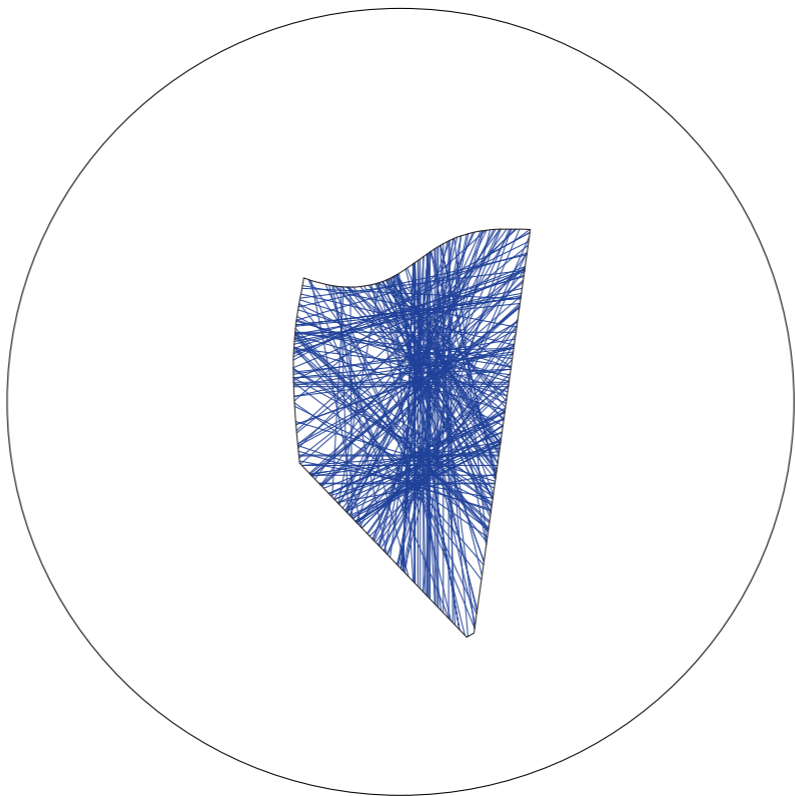
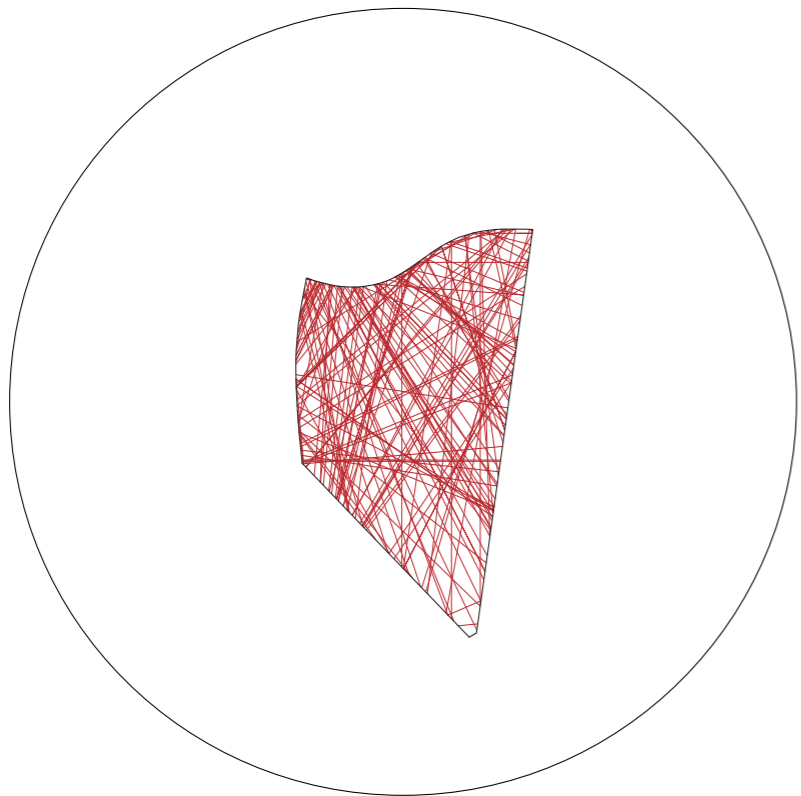
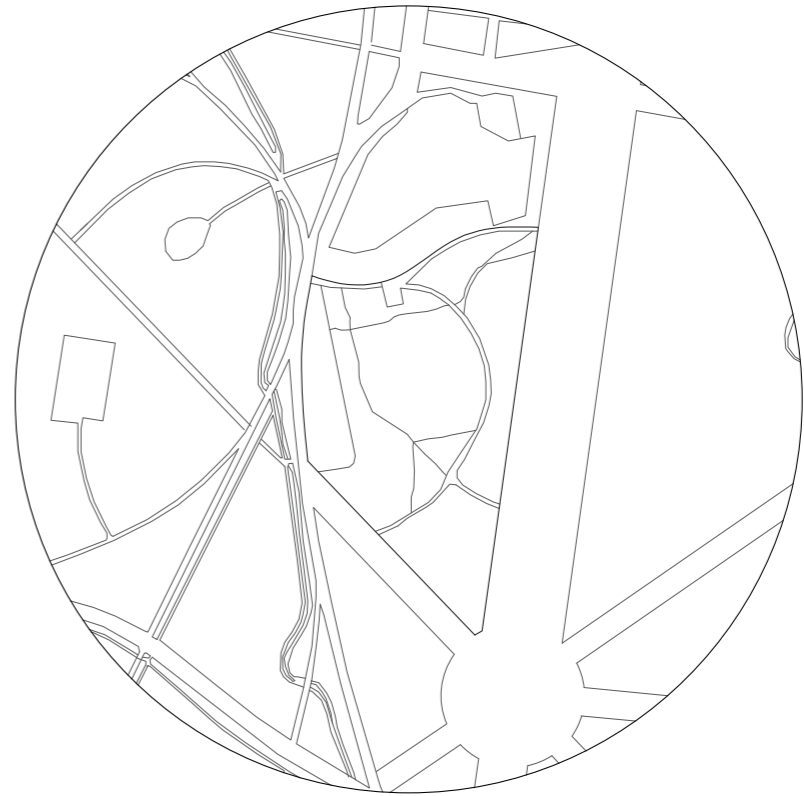
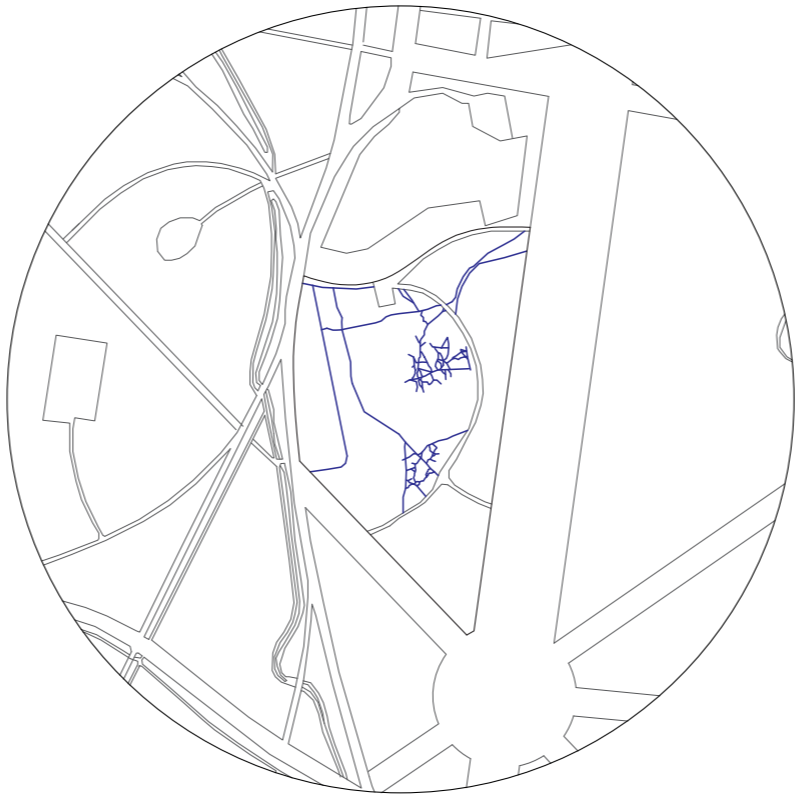
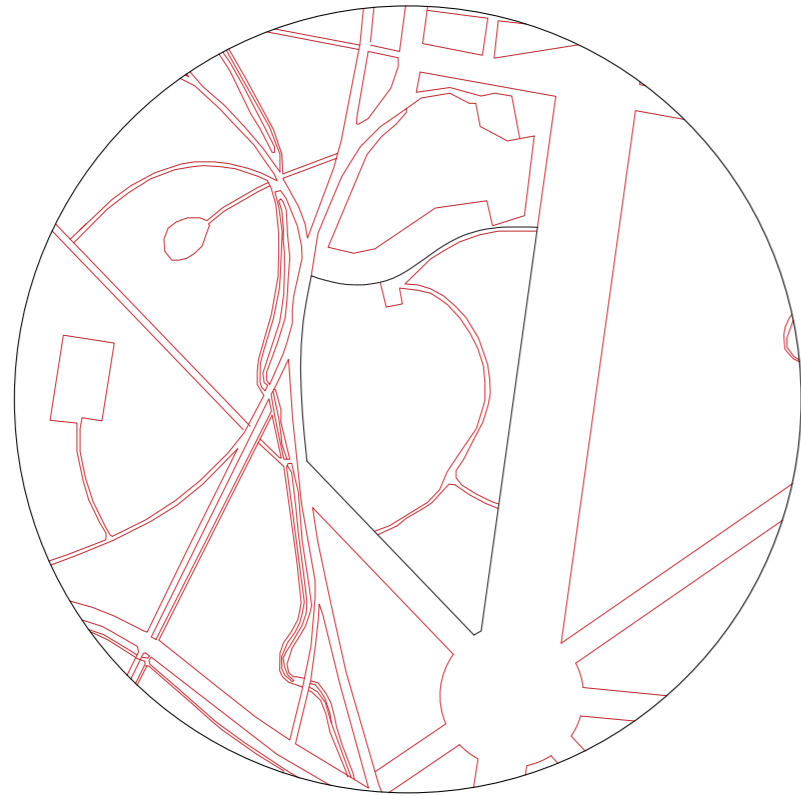

Existed paths

Kemono-michi

Intersection of paths

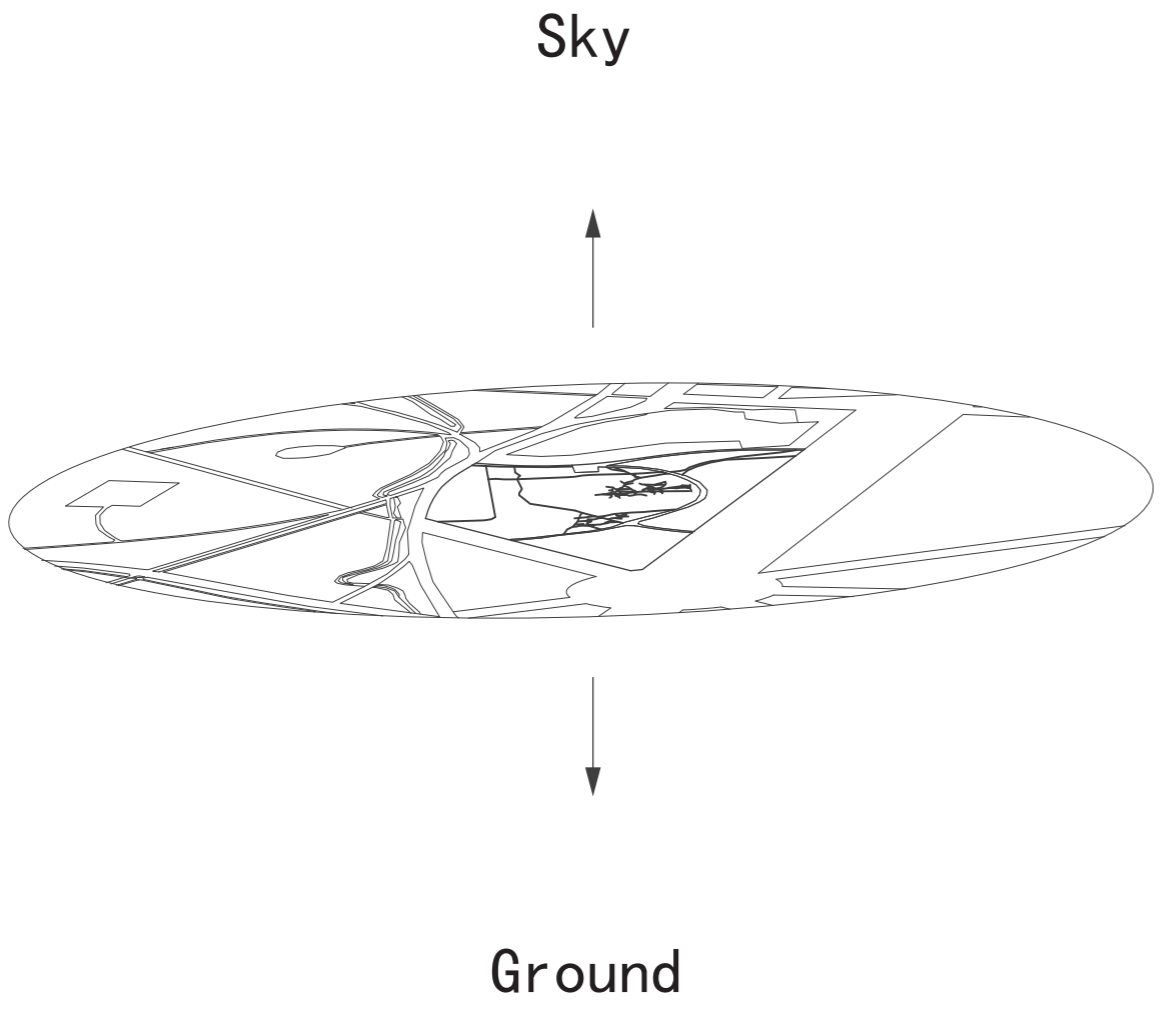

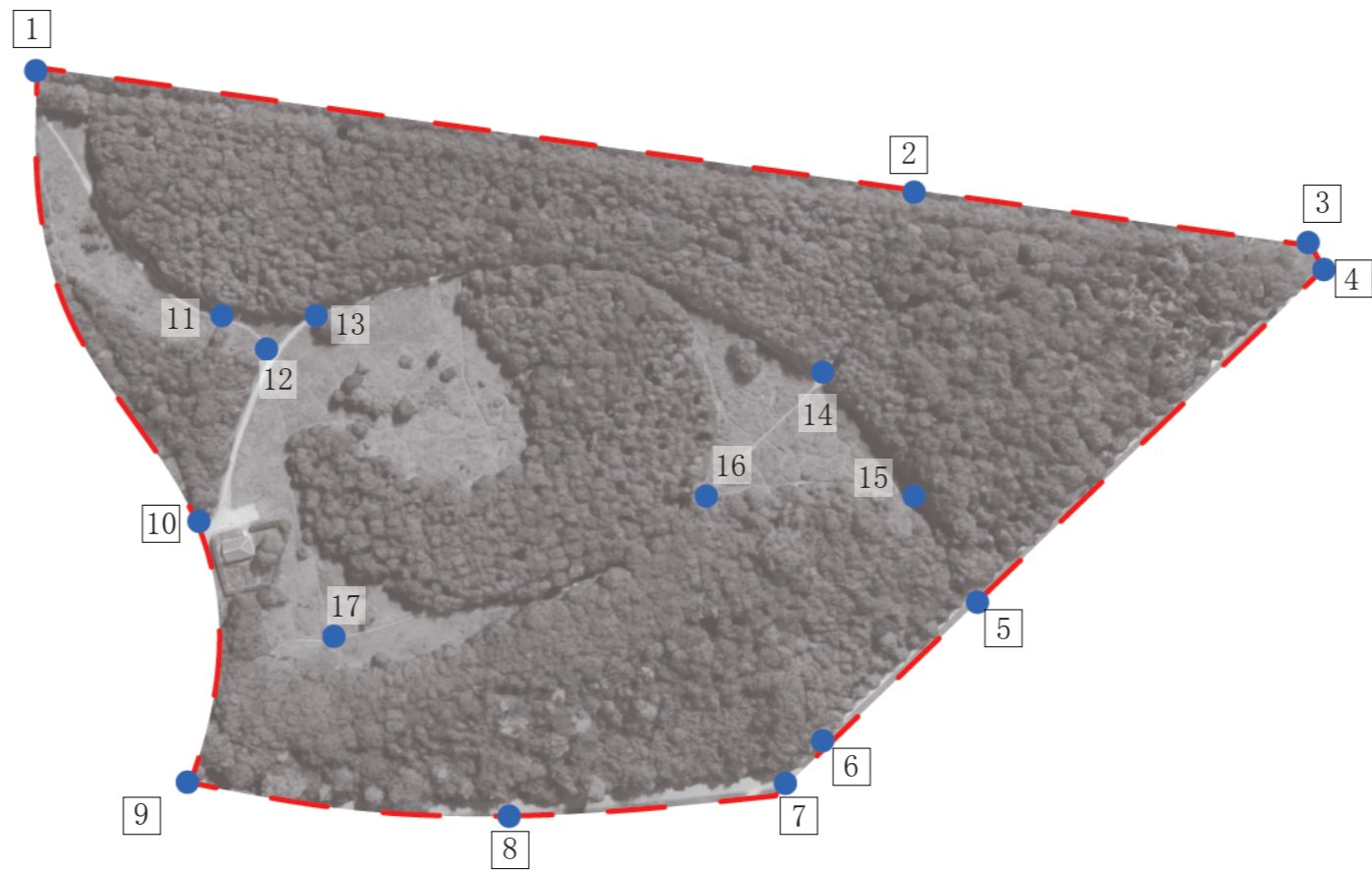

SKY

GROUND



1 2 3 4 5 6 7 8



9 10 11 12 13 14 15 16 17

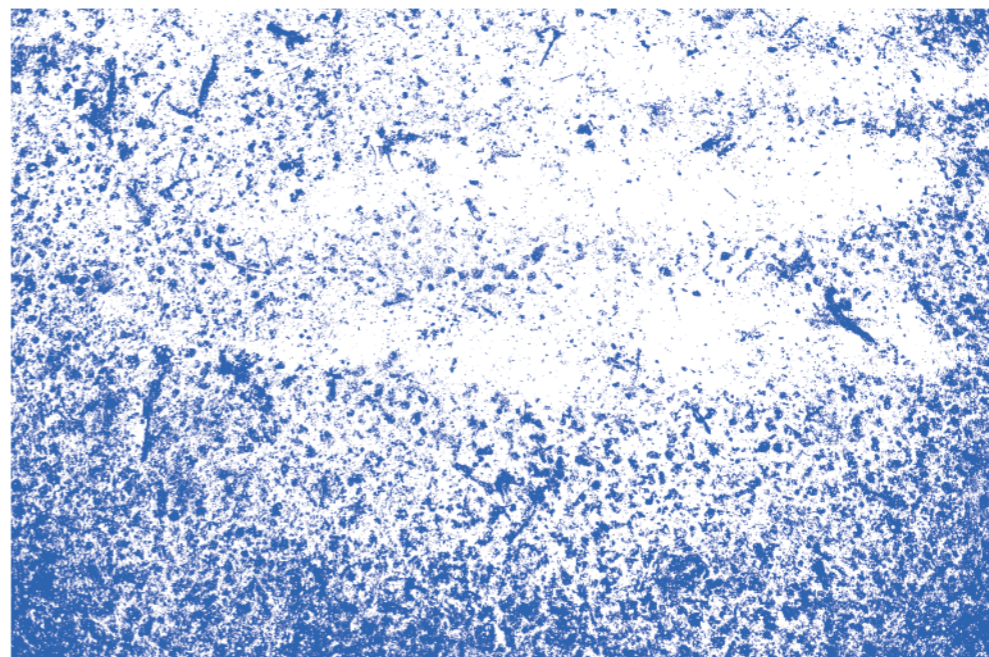
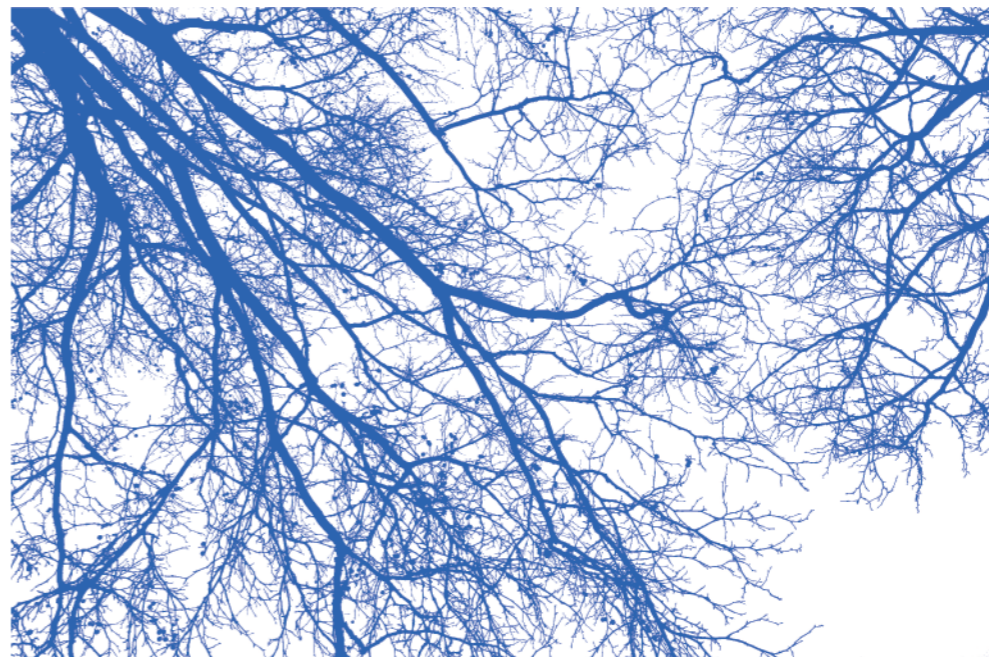

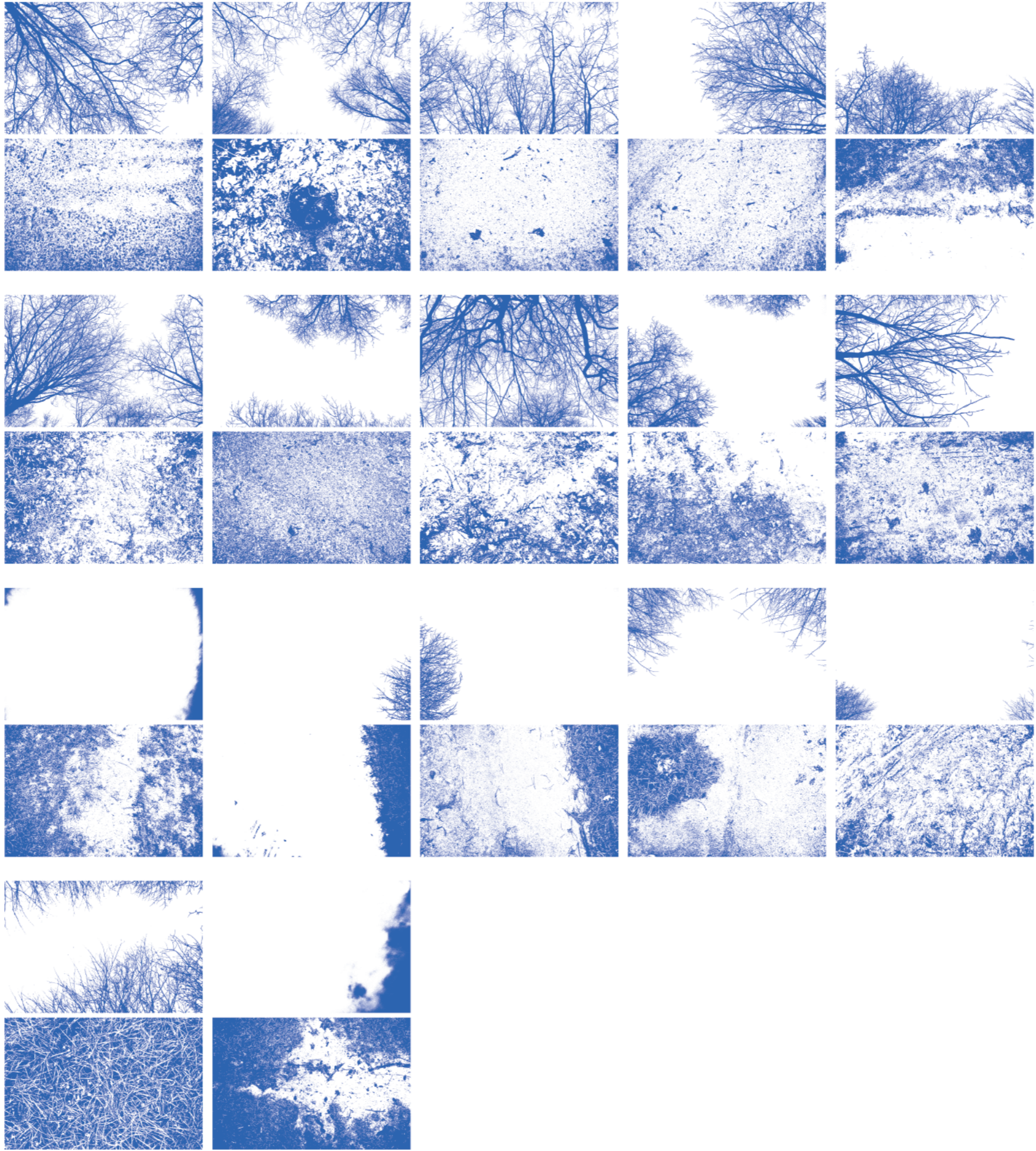

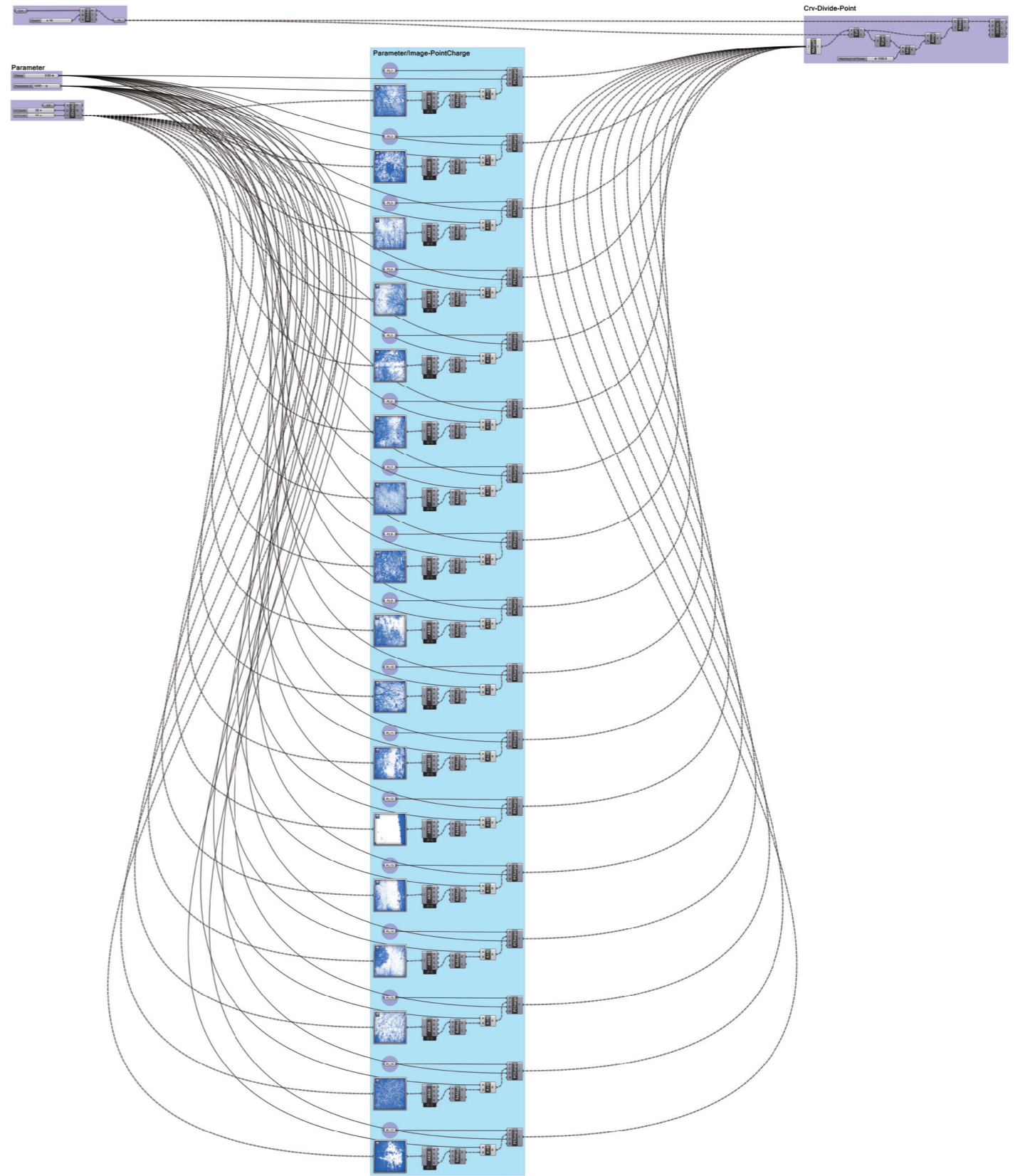
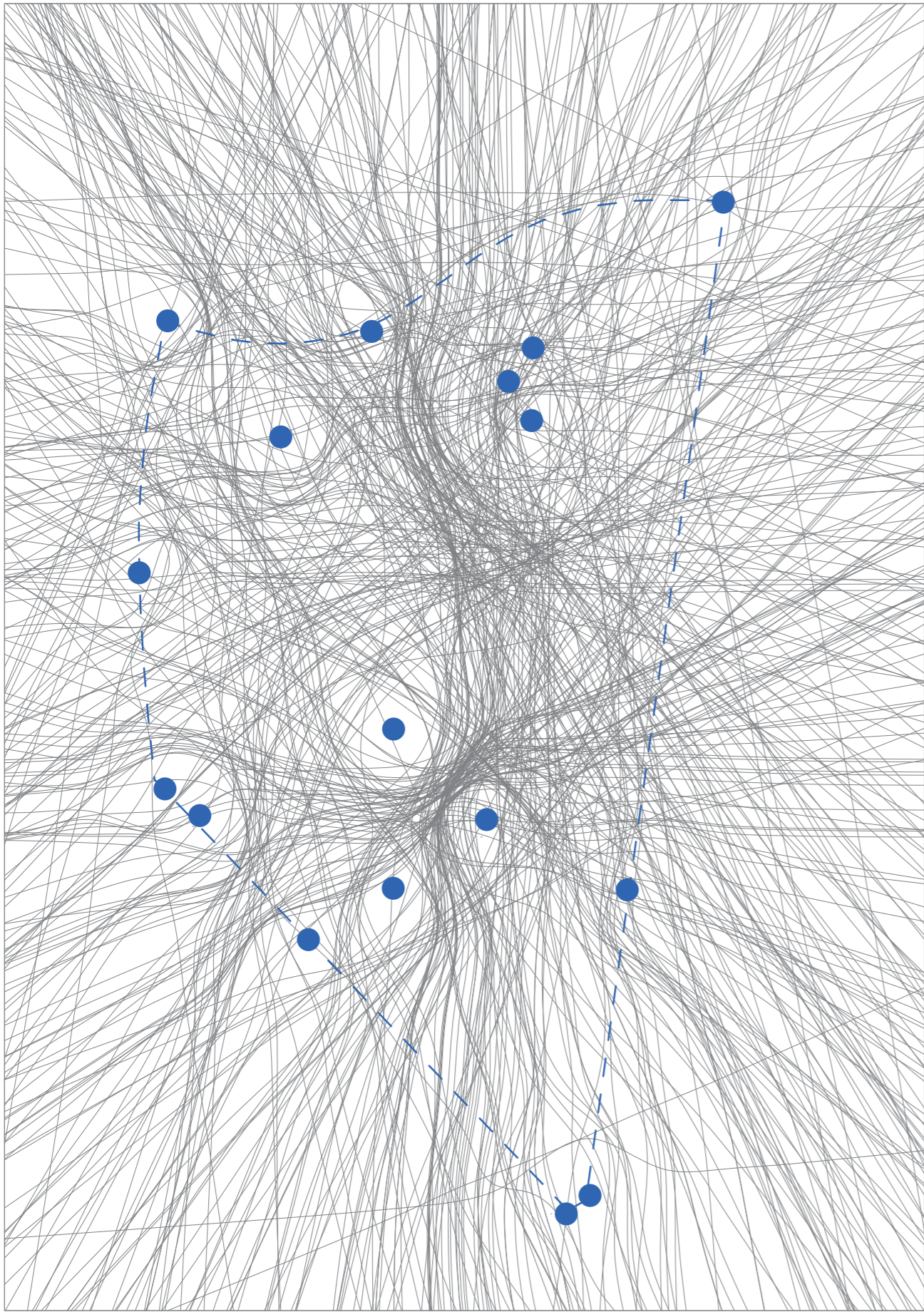

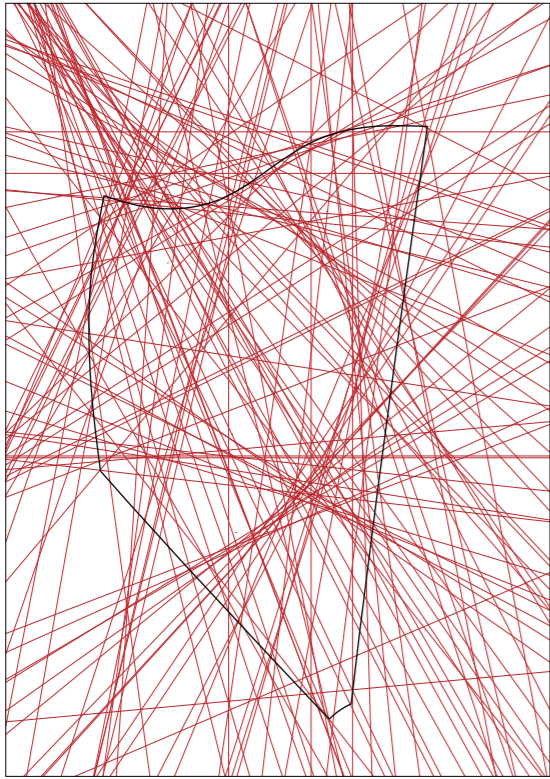

Extended Paths

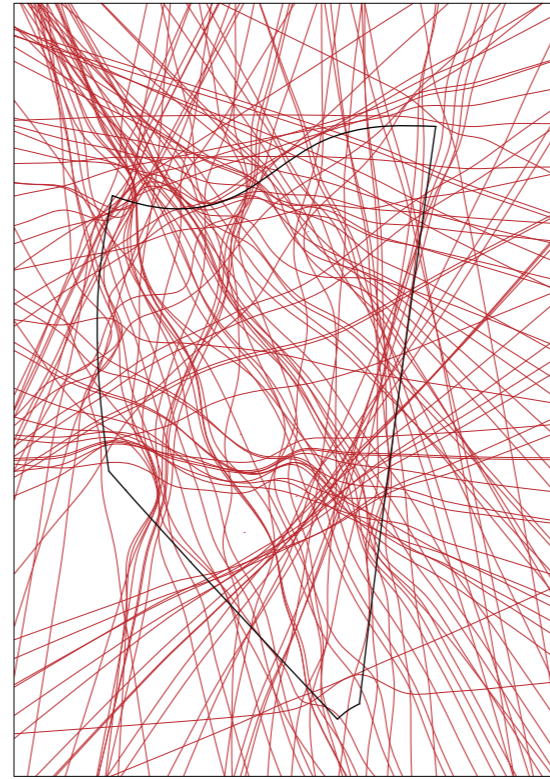
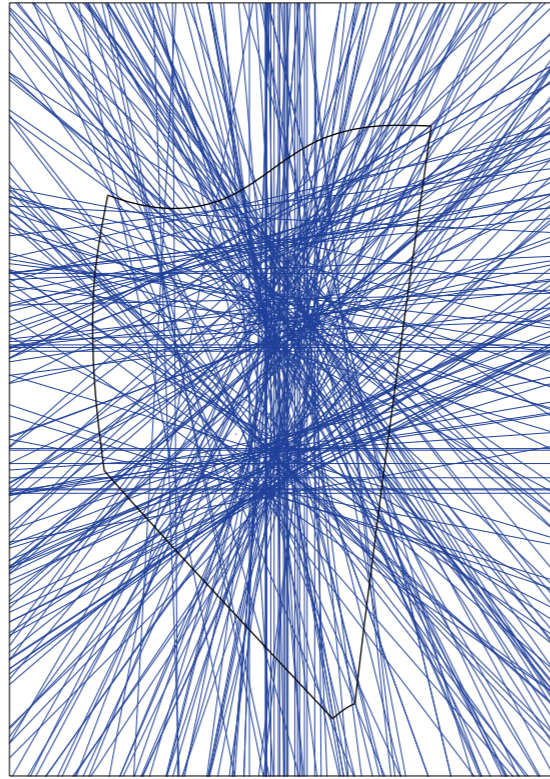

Distorted Paths

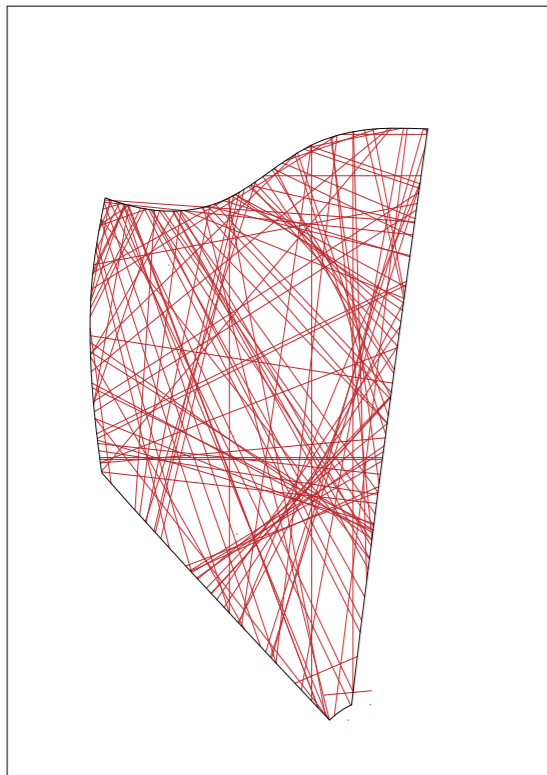
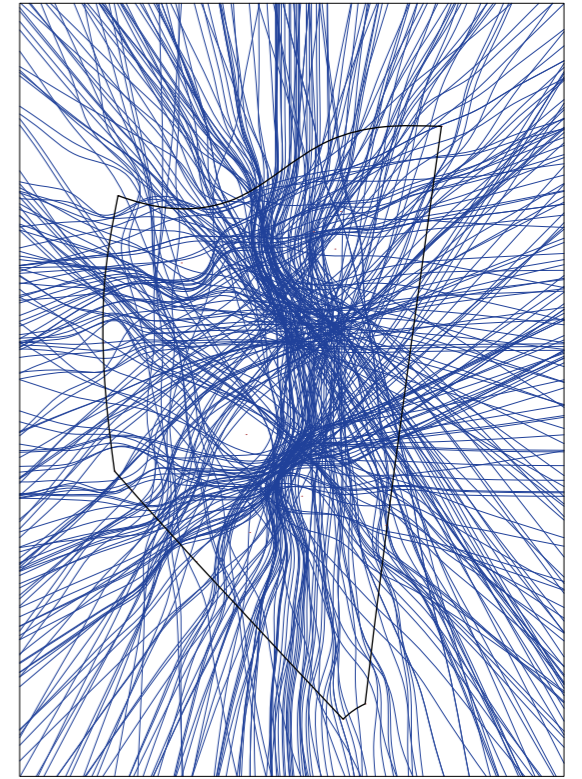

Existed paths

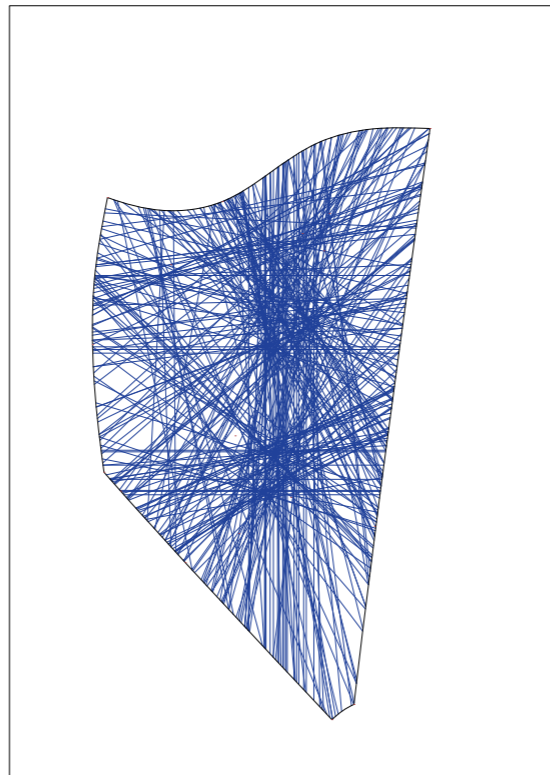

Kemono-michi

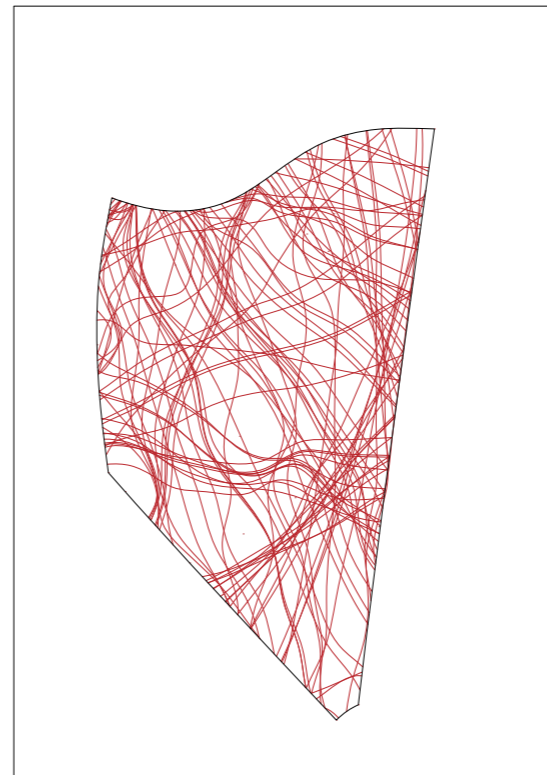

Existed paths

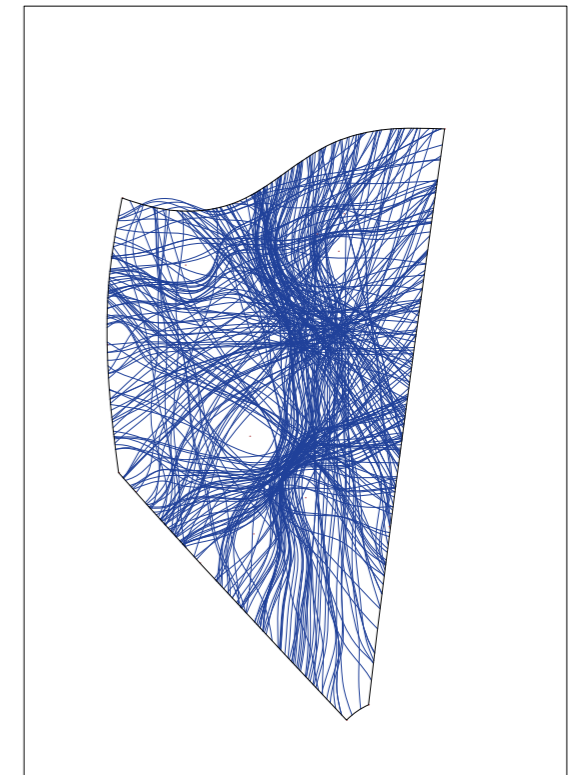

Kemono-michi

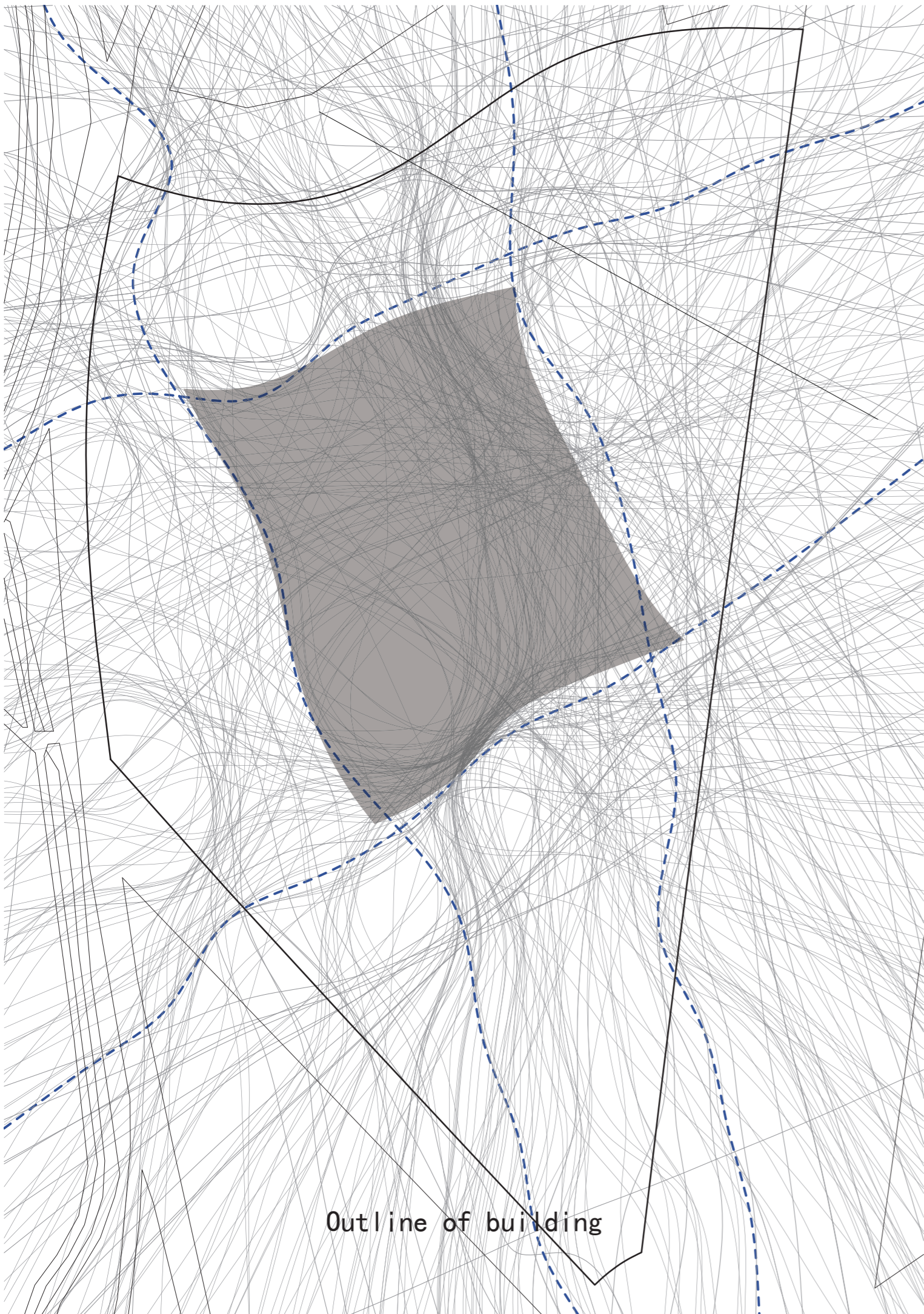

Outline of building

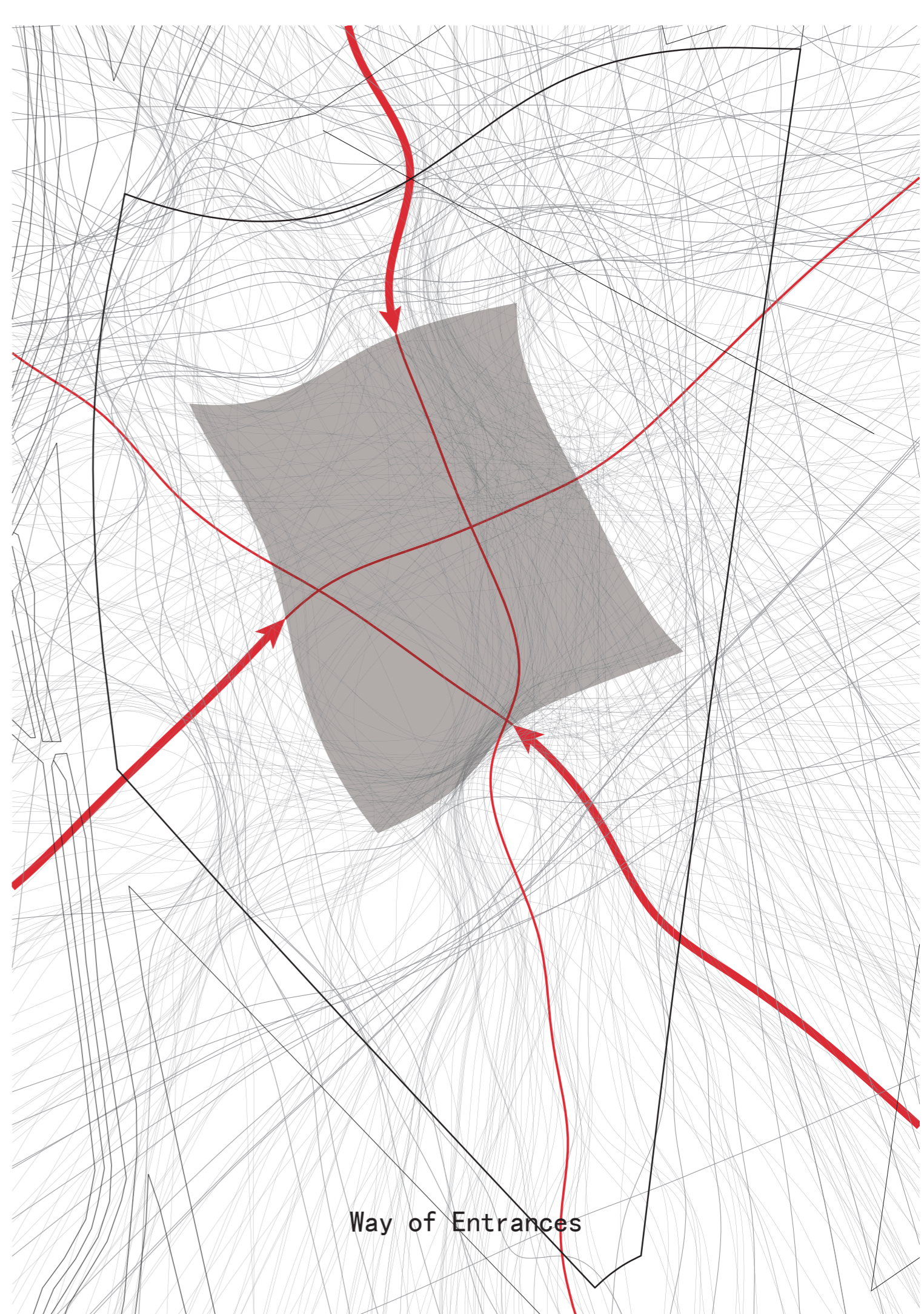

Way of Entrances

4. Form

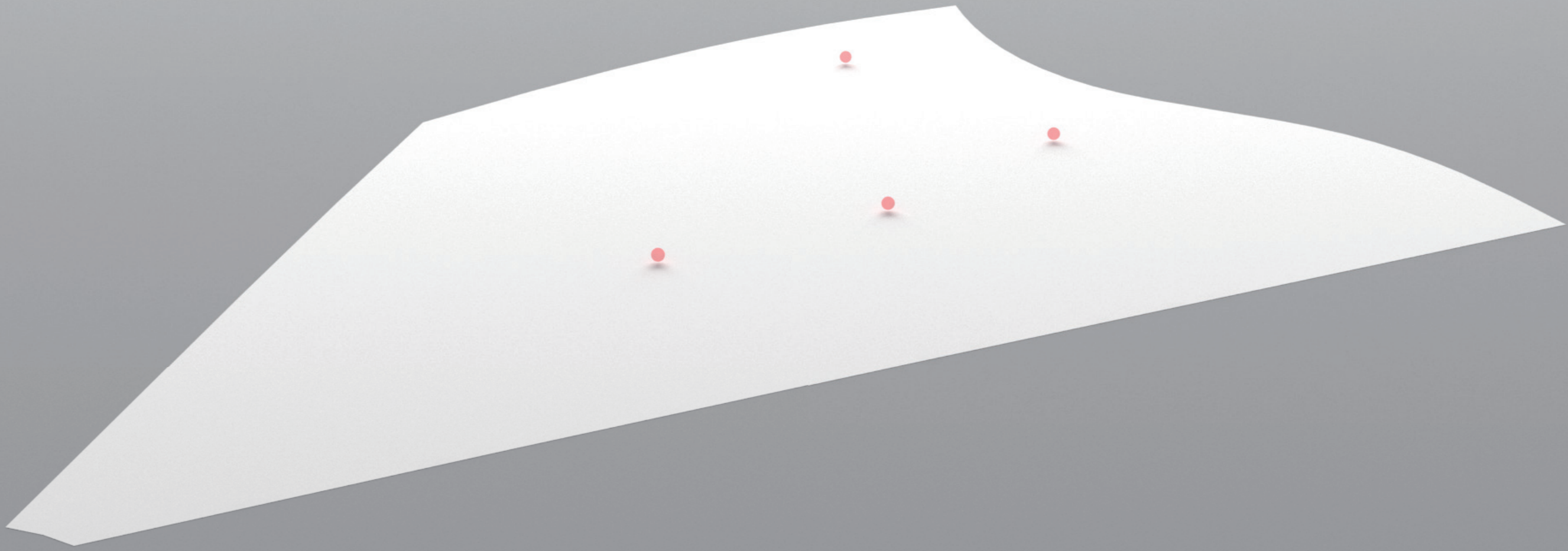

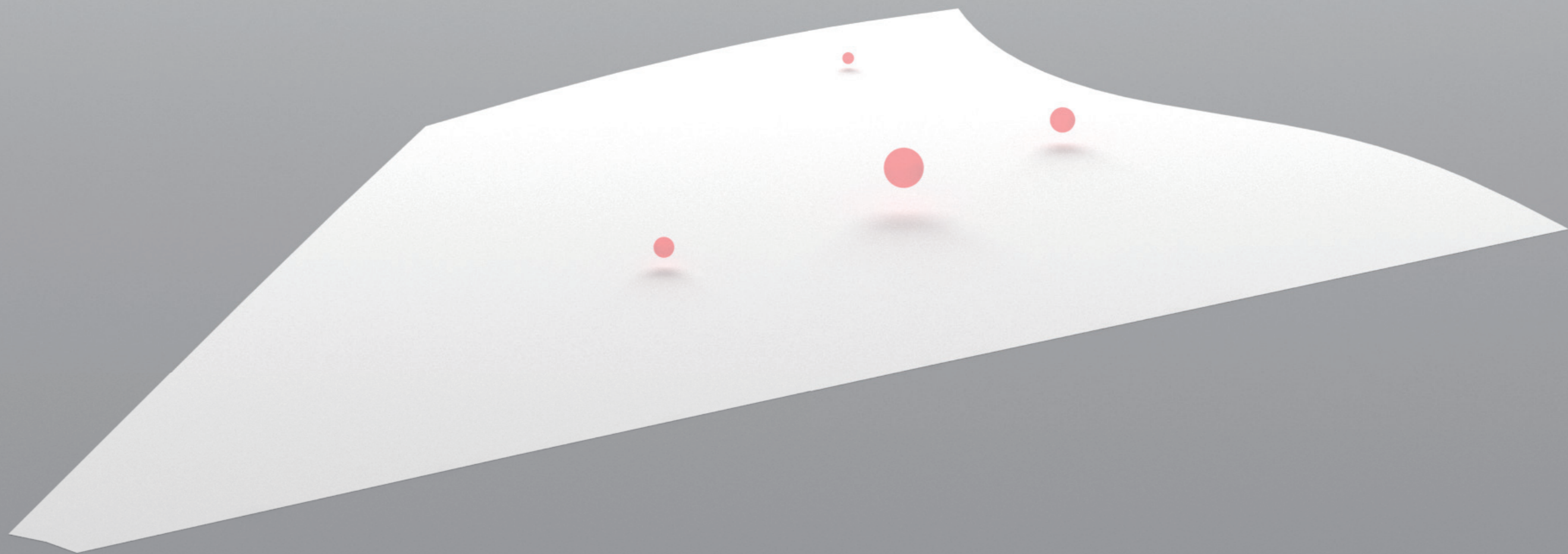

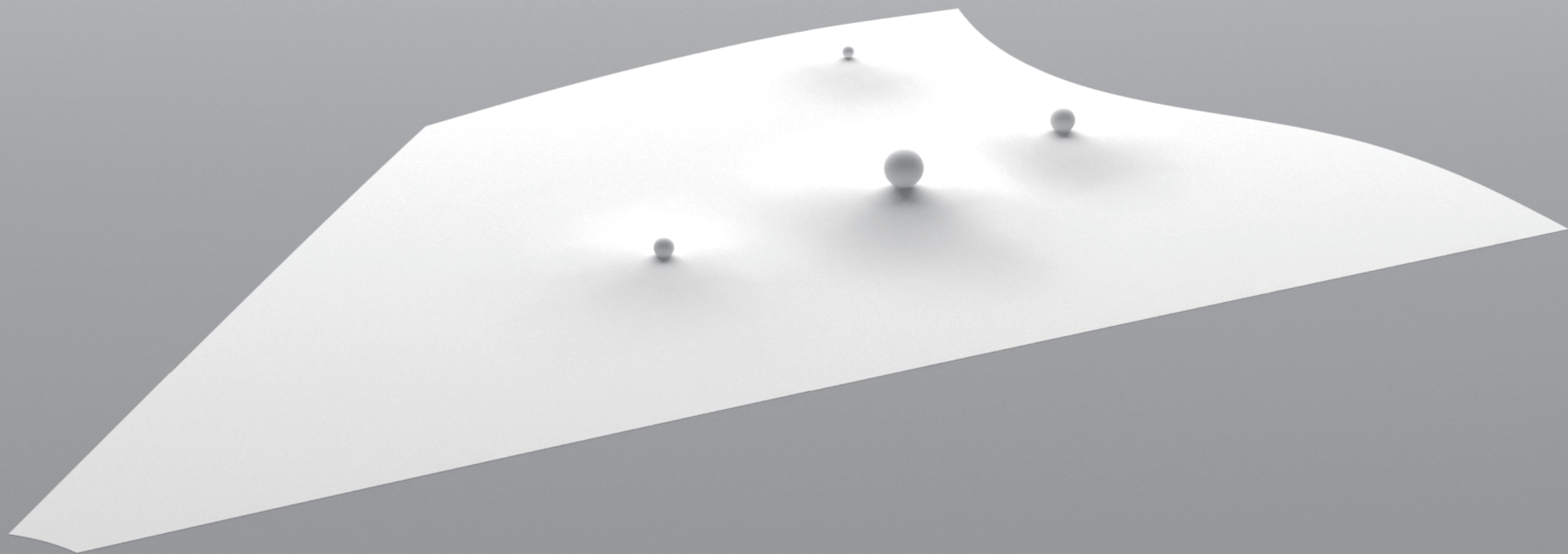

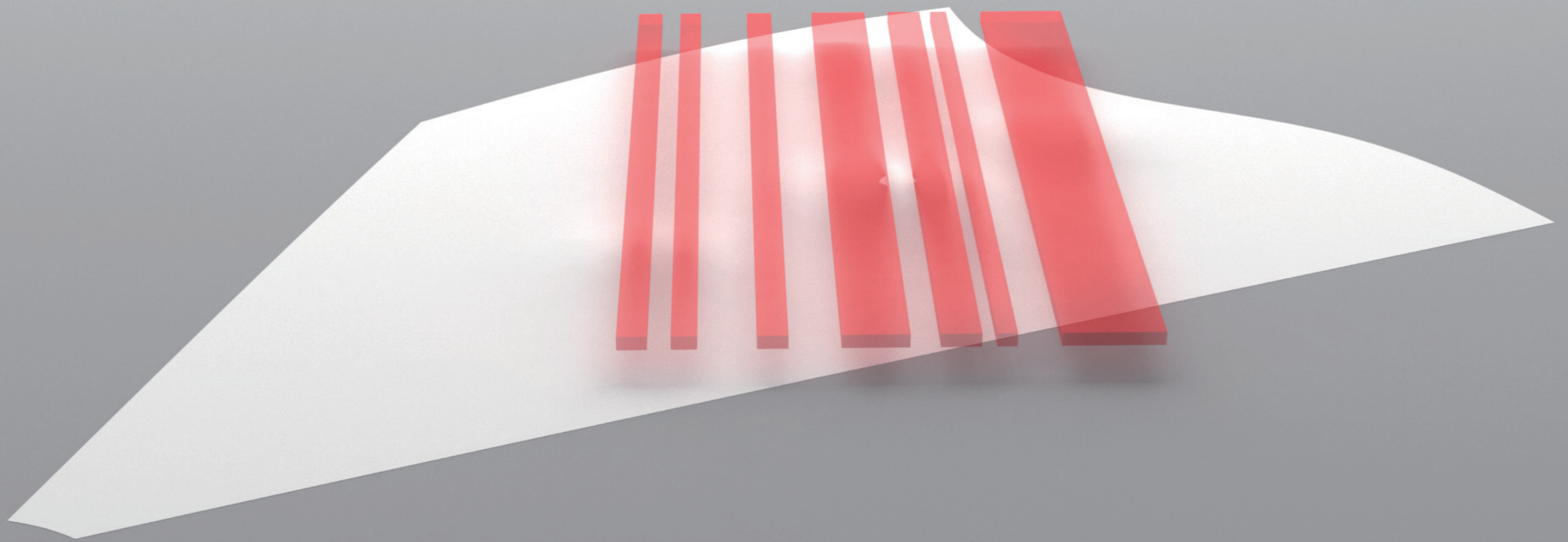

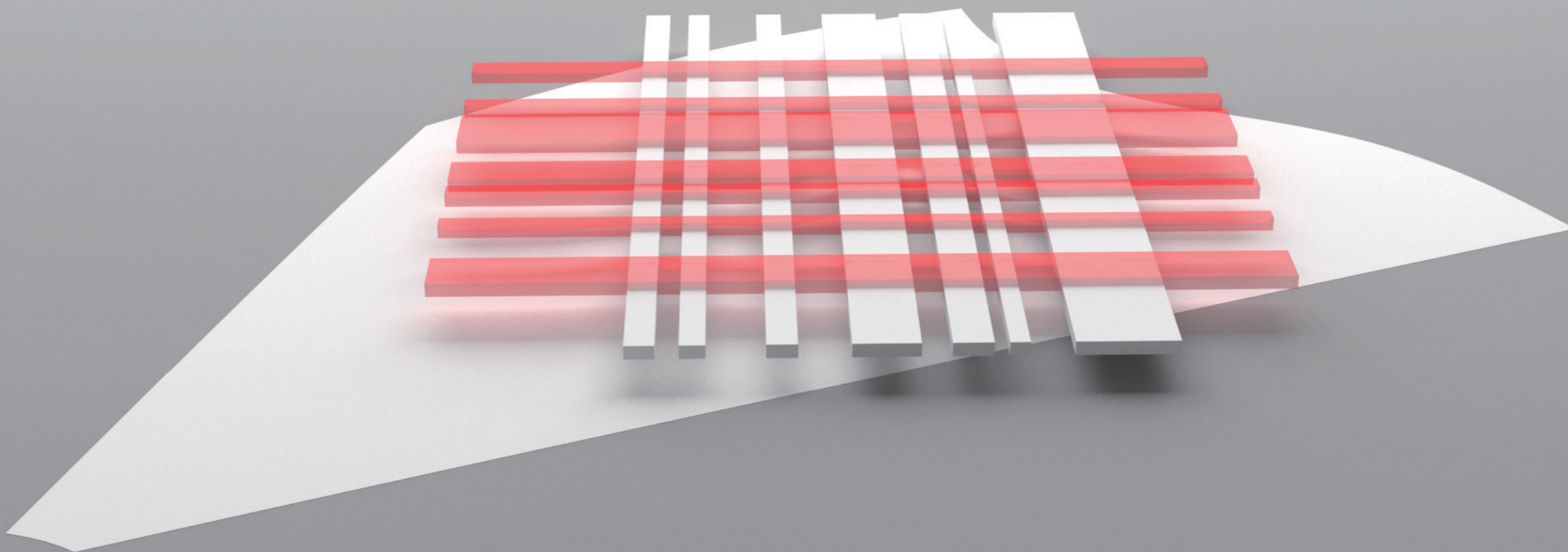

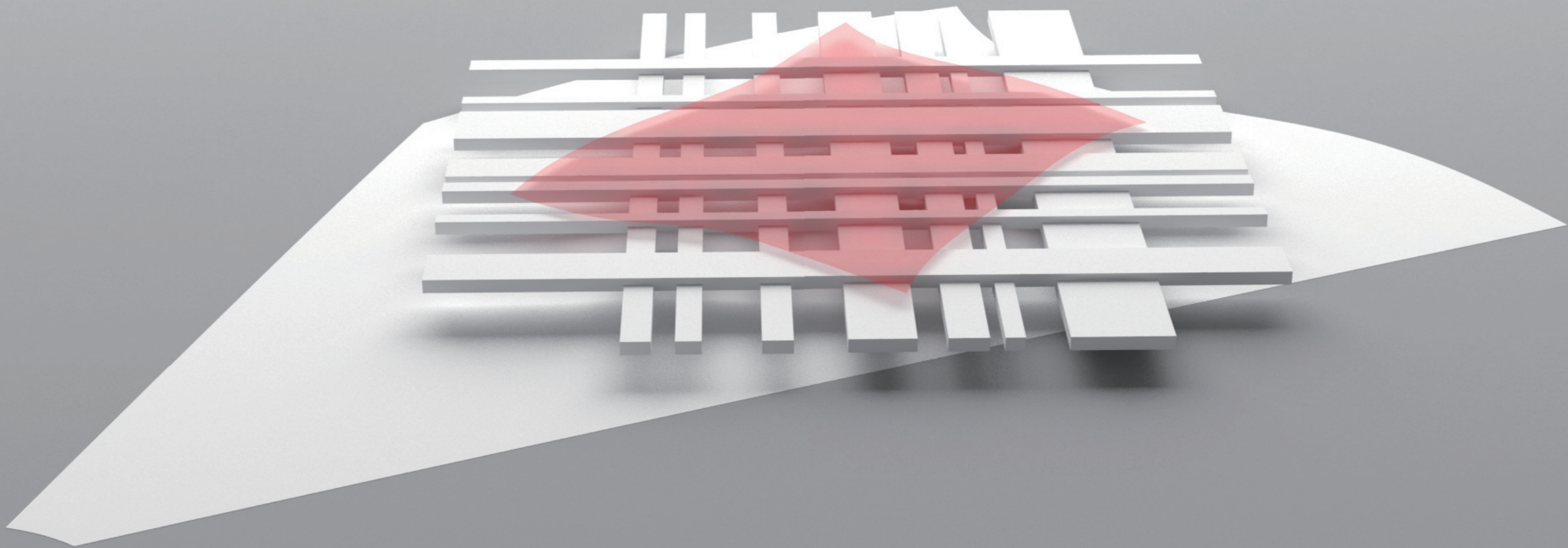

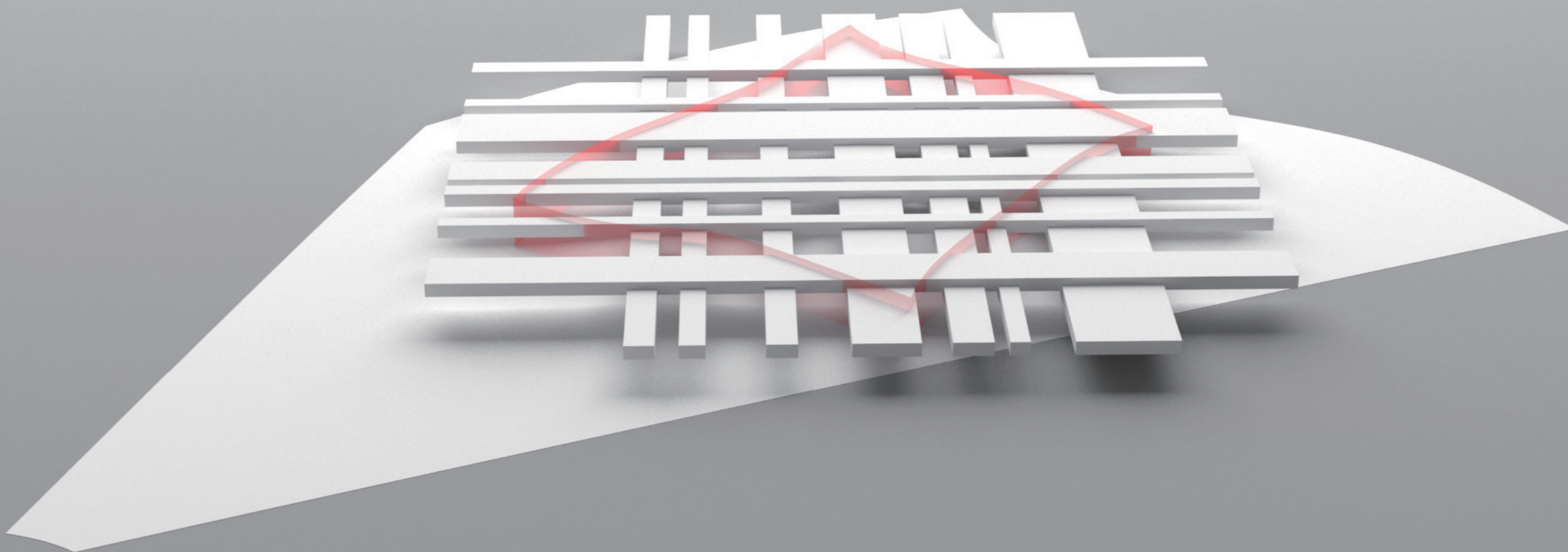

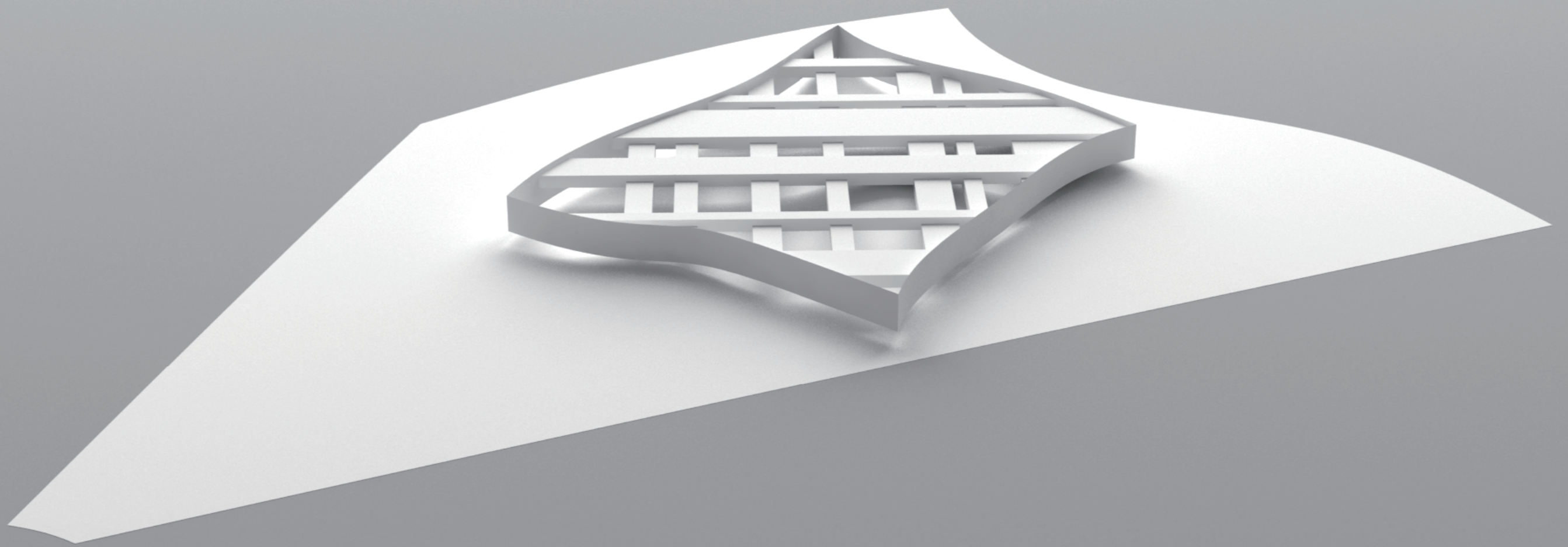

5. Masterplan

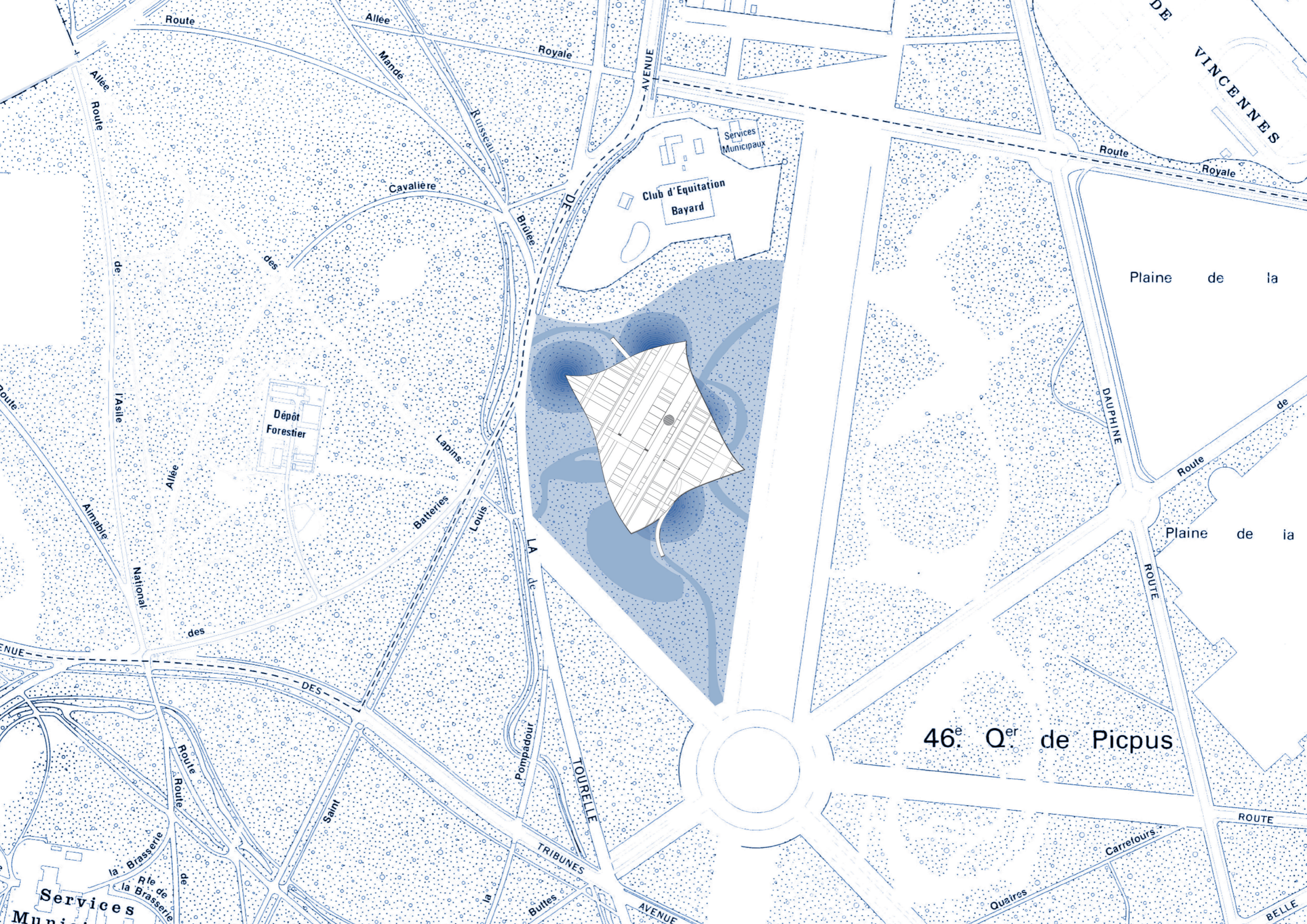

Plaine de la

Plaine de la

46^e Q^{er} de Picpus

Services Municipaux

Club d'Equitation Bayard

Dépôt Forestier

Services Municipaux

Route

Allée

Royale

AVENUE

Route

Royale

DAUPHINE

Route

ROUTE

ROUTE

Carrefours

Quatres

BELLE

Rousseau

Cavaliere

Bulee

des

Lapins

Batteries

Louis

LA de

Pompadour

TOURELLE

TRIBUNES

Buttes

AVENUE

Allee

Aimable

Allée

de

National

des

DES

Saint

Route

de

Rte de la Brasserie

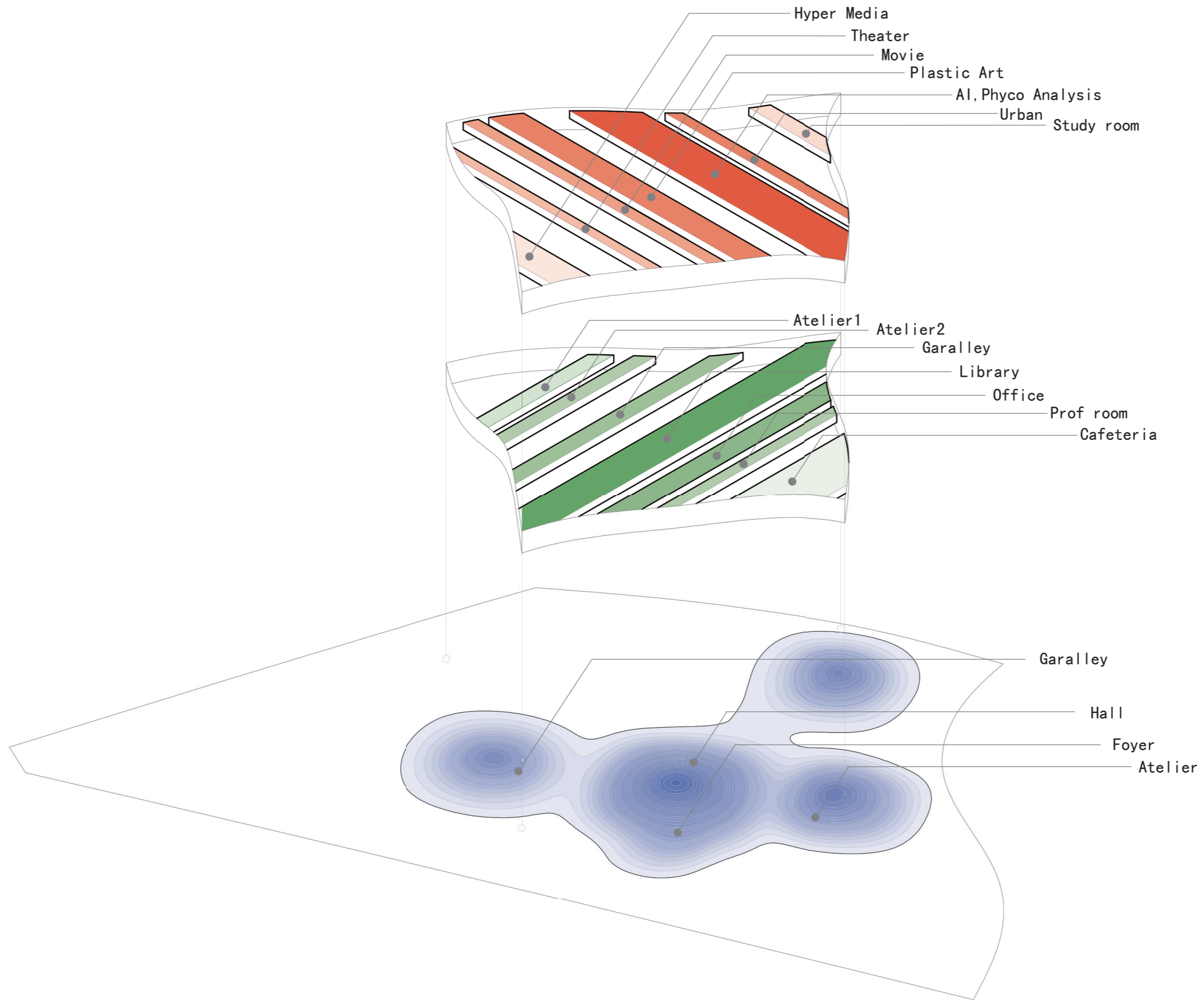

Program

6. Perspective



Elevation from south



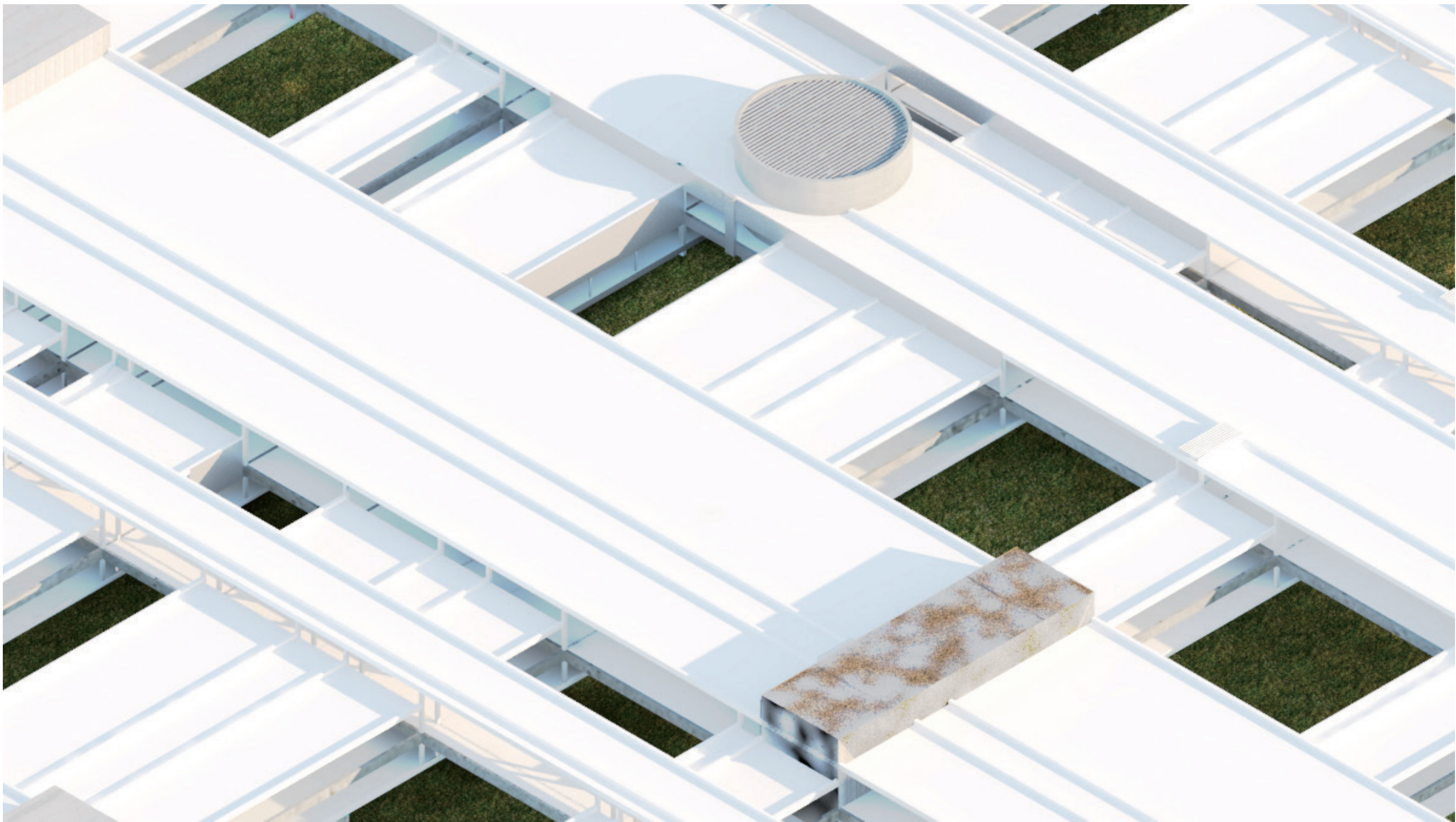



Main entrance

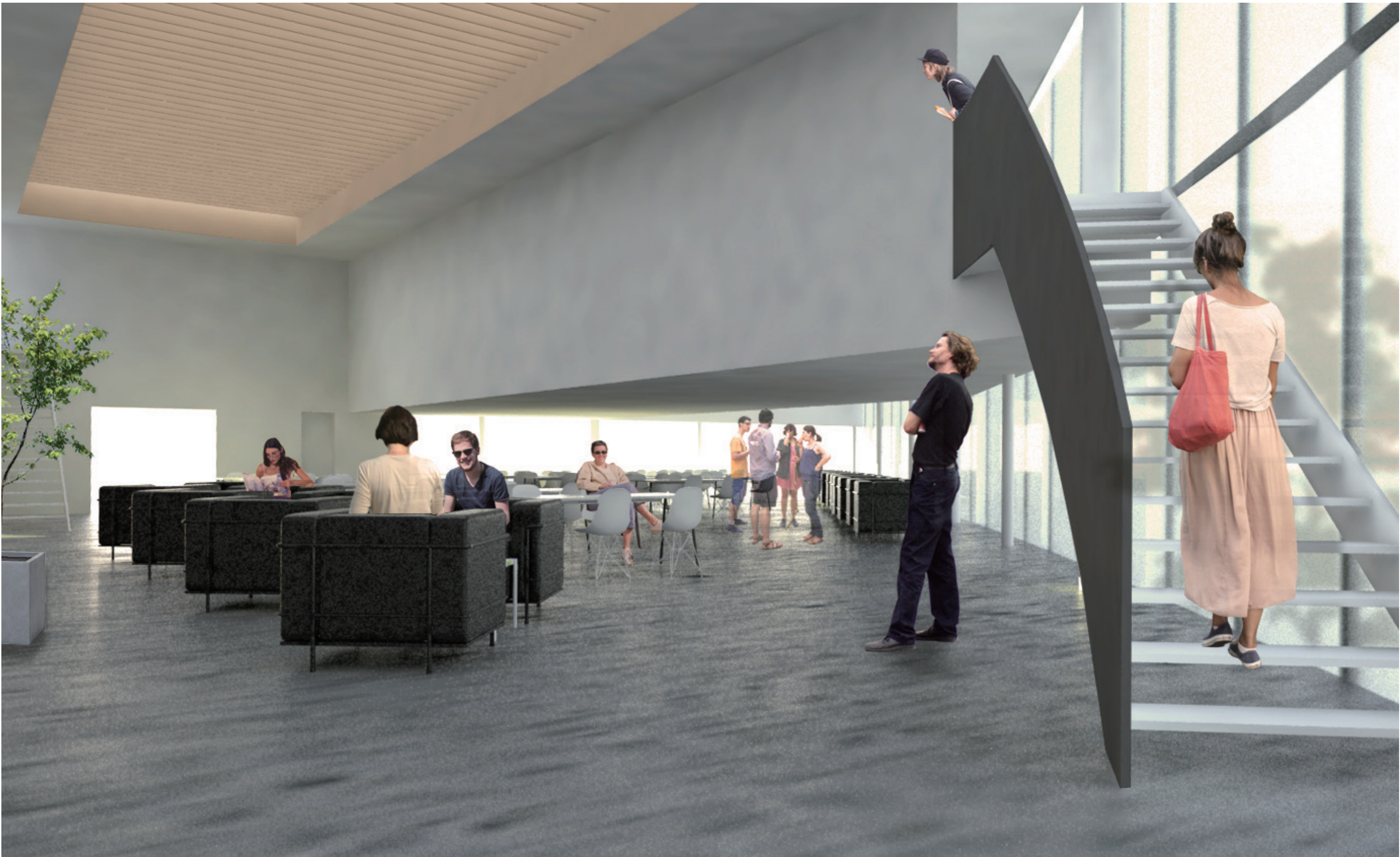

Cafeteria

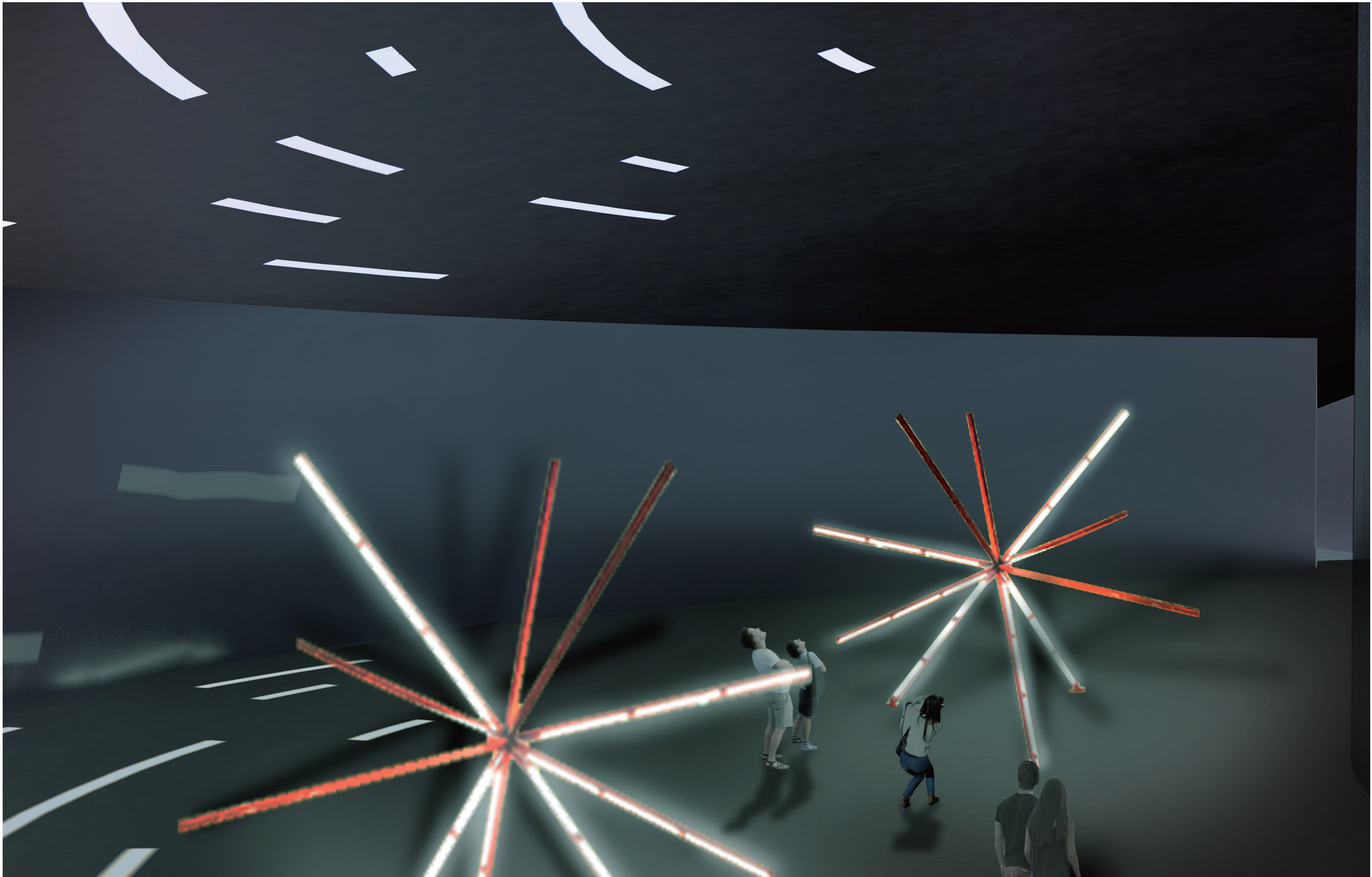

Foyer

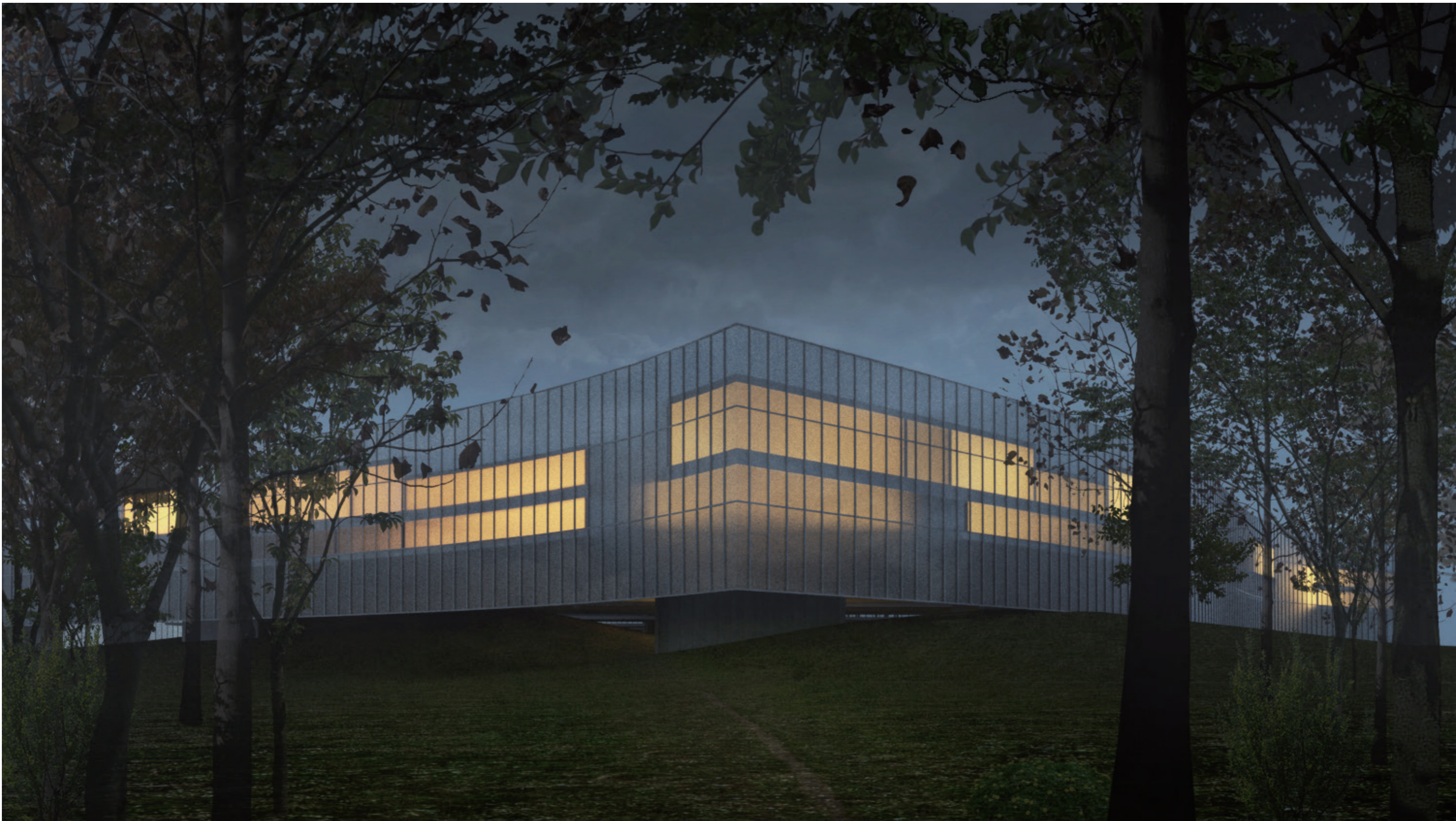

Night view

7. Drawing

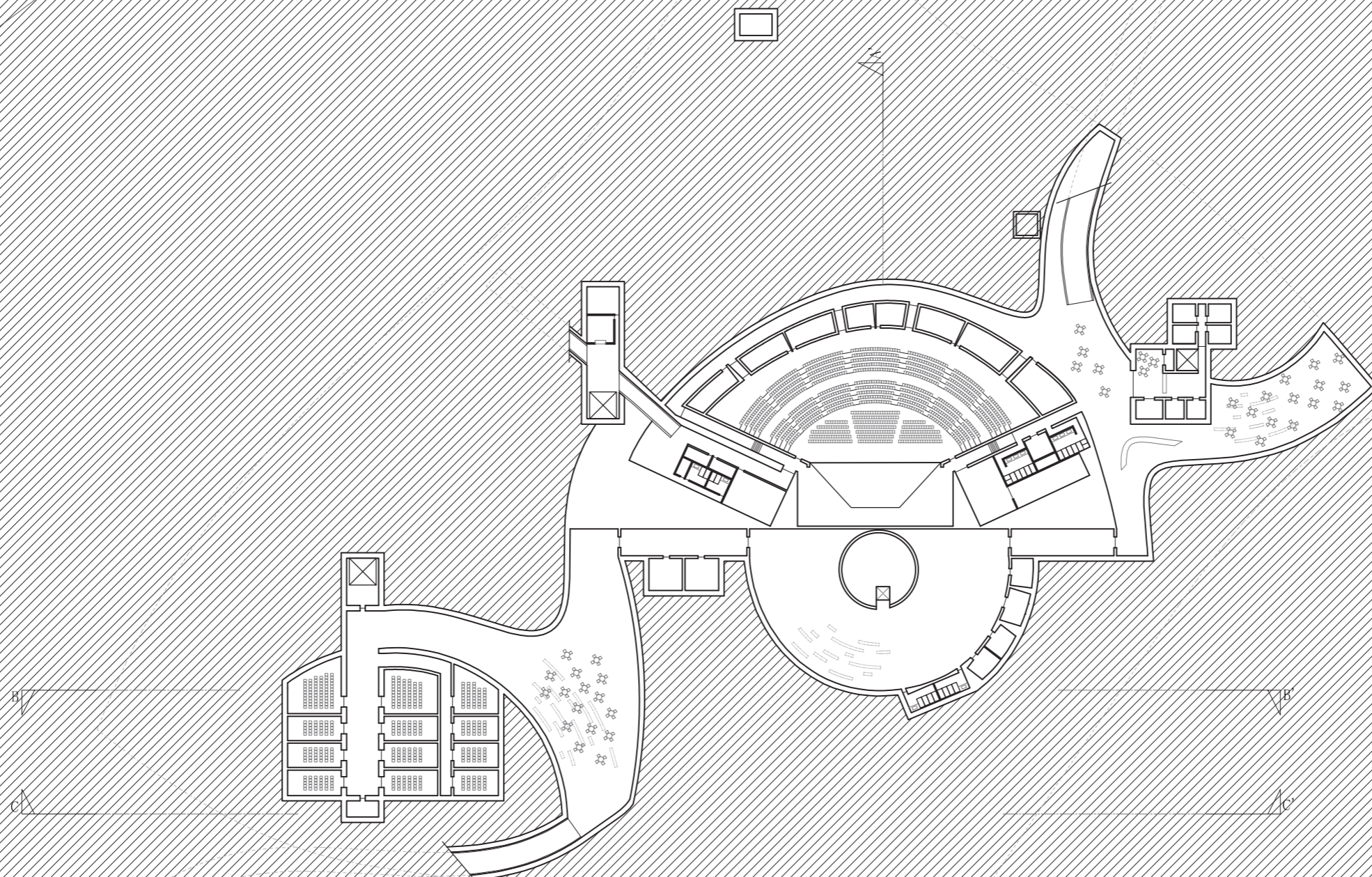

B1 Drawing

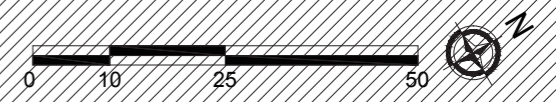

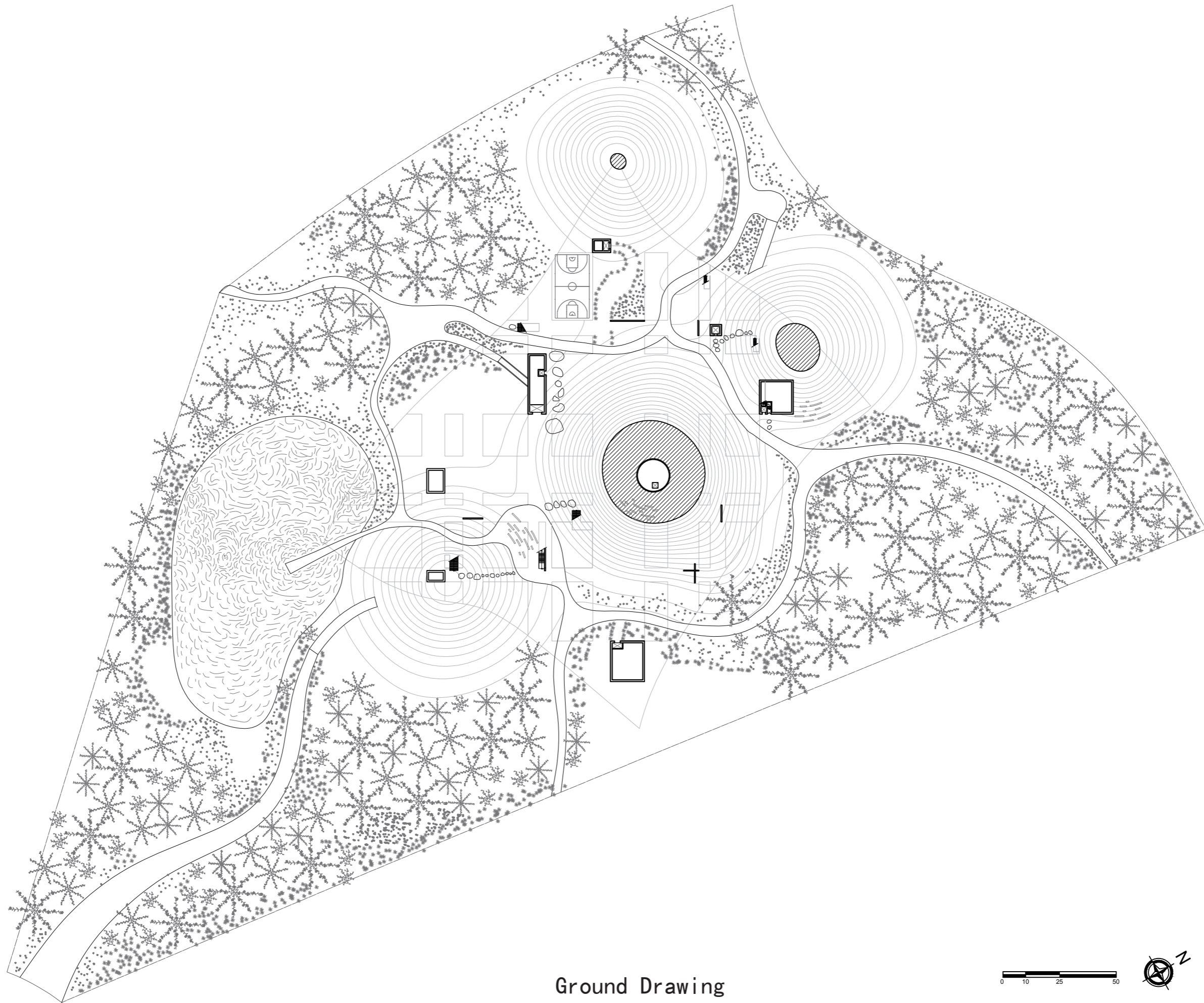

Ground Drawing



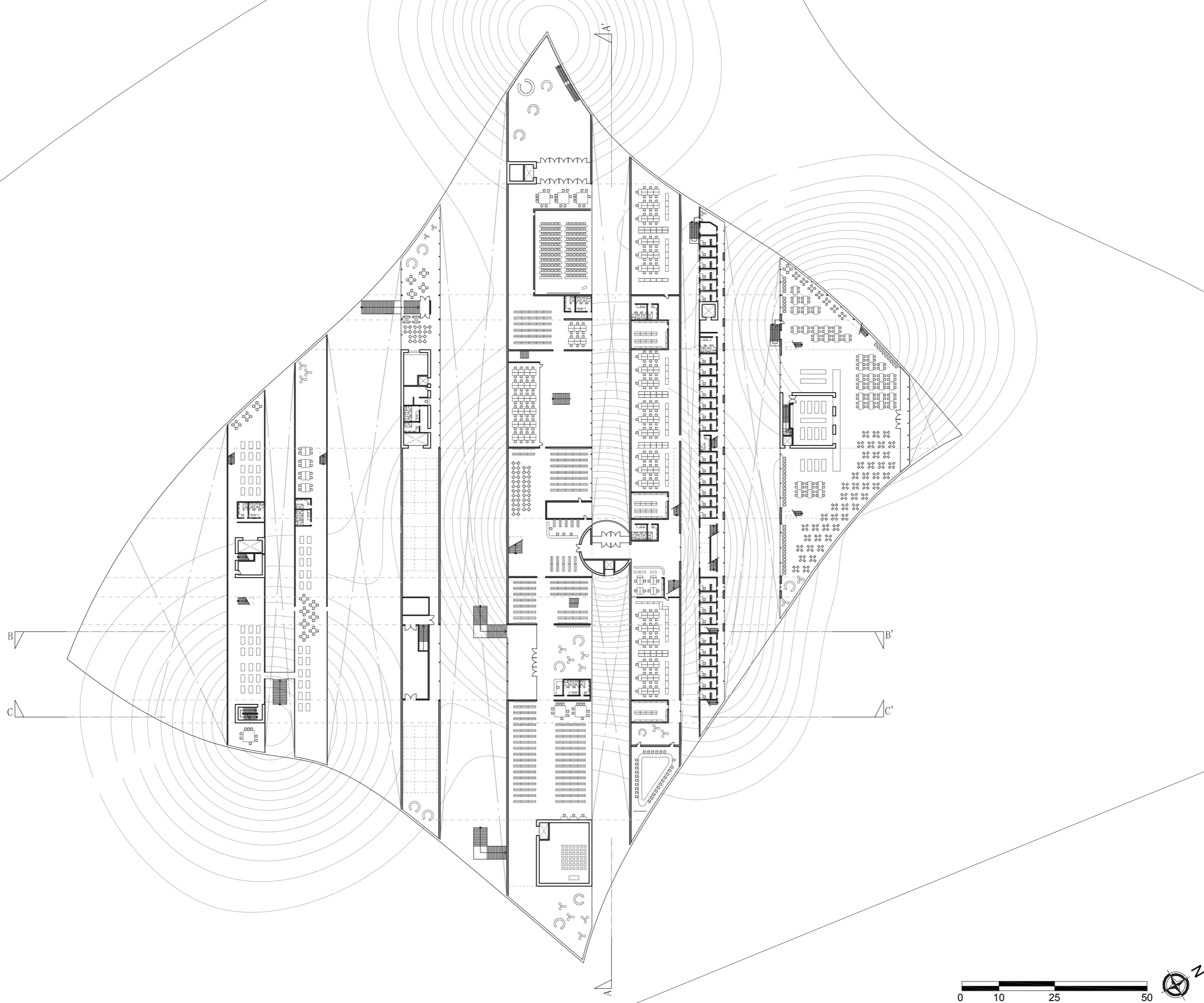

1F Drawing

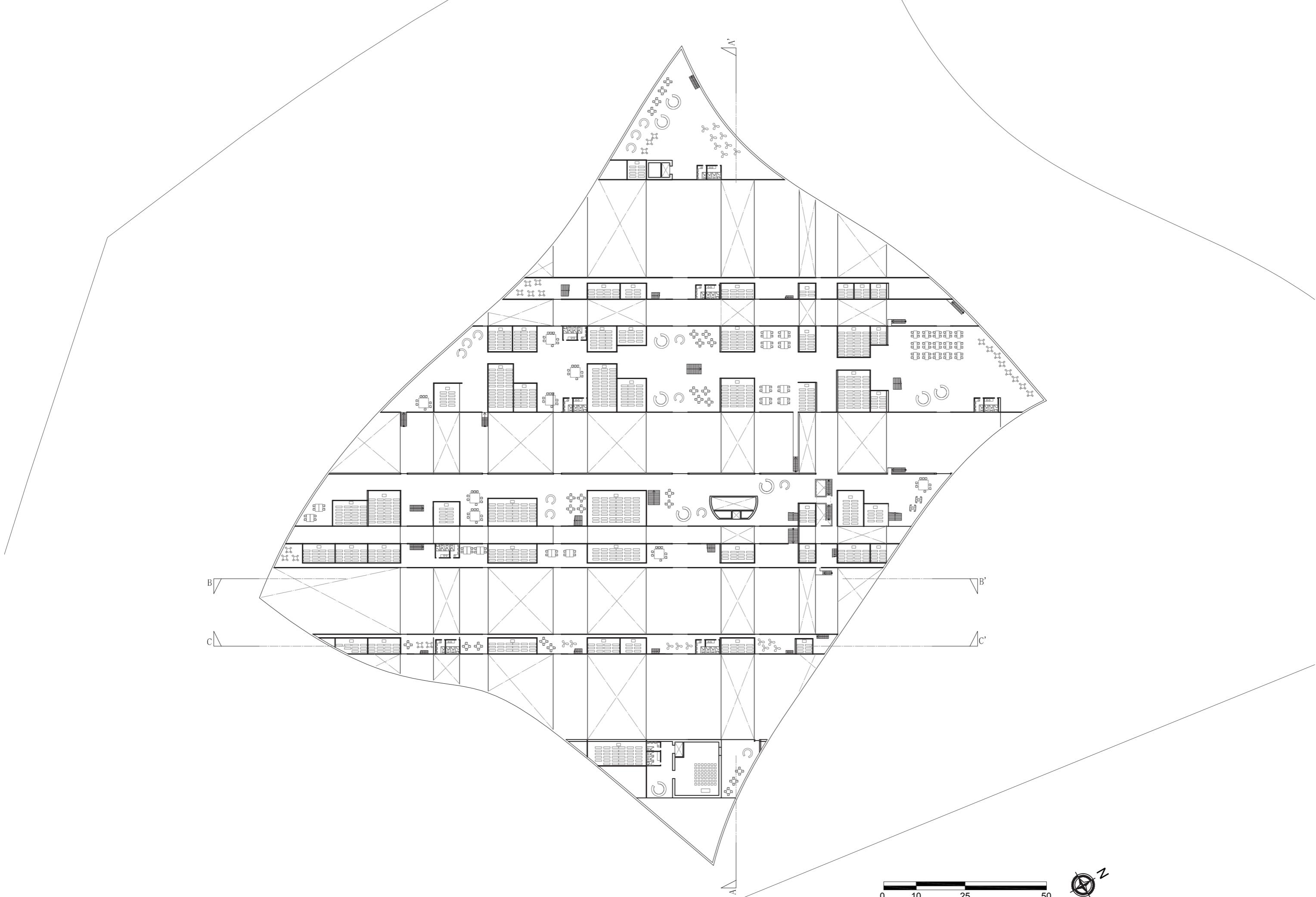

2F Drawing

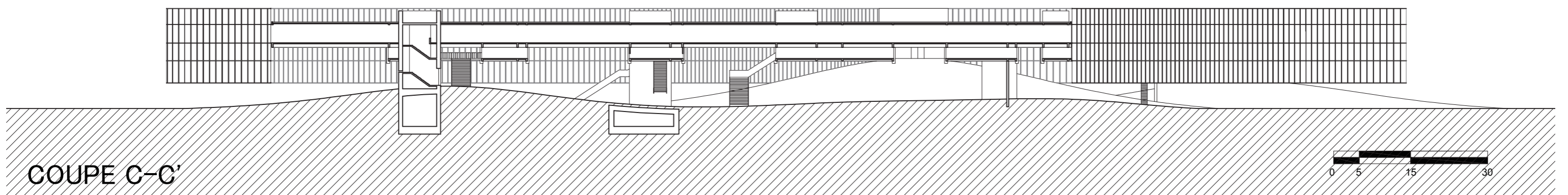
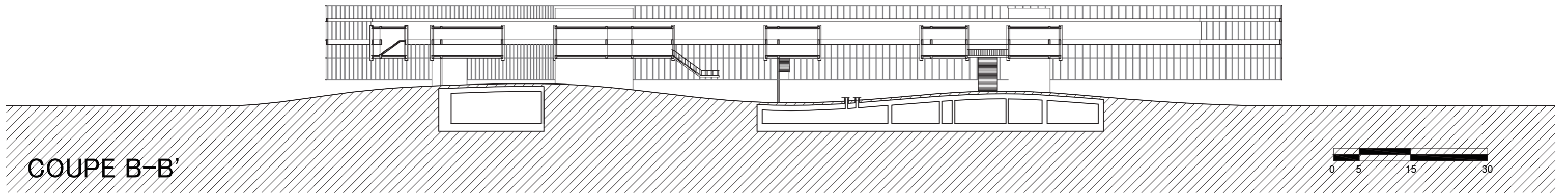
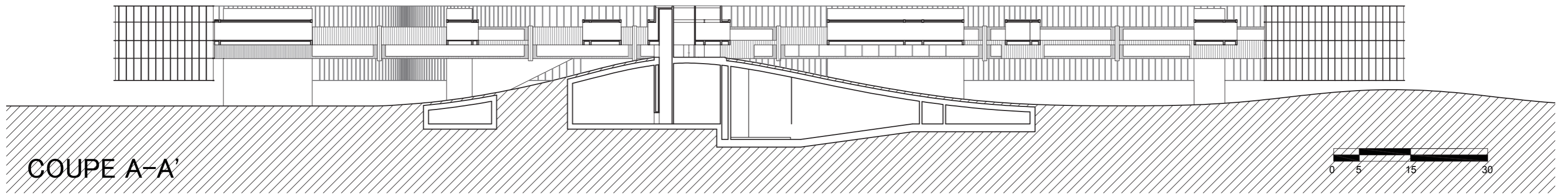

Section

8. Detail

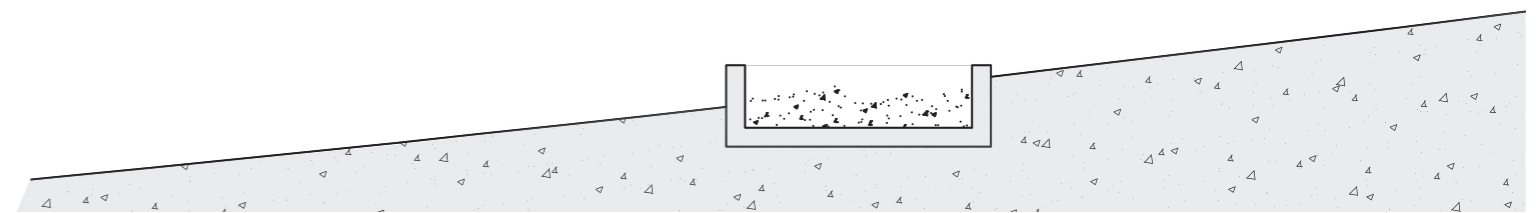
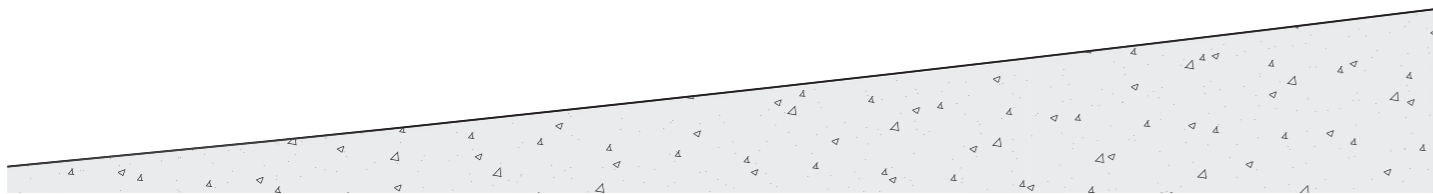
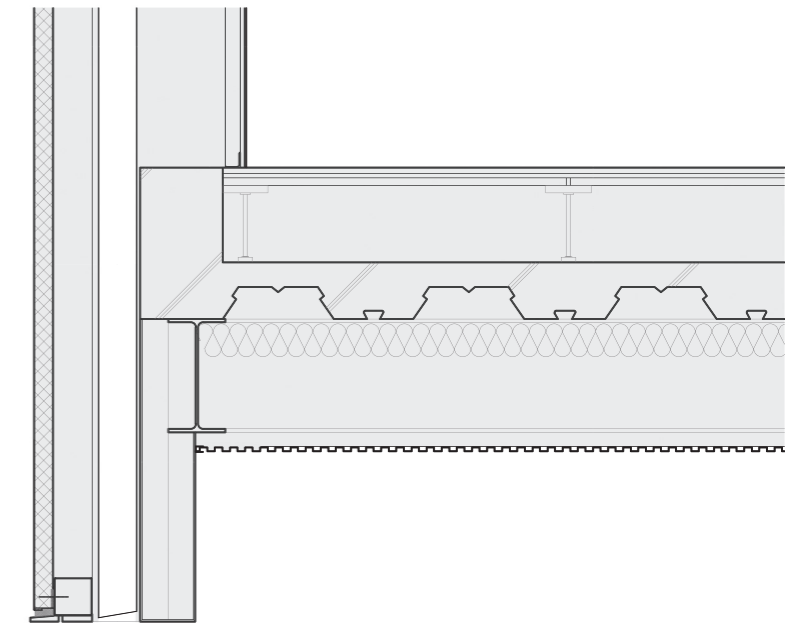
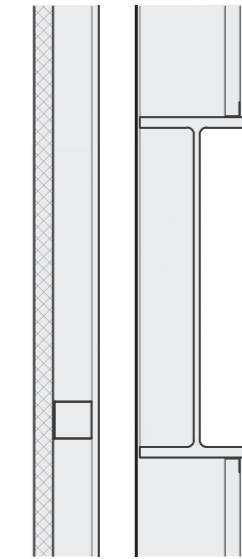
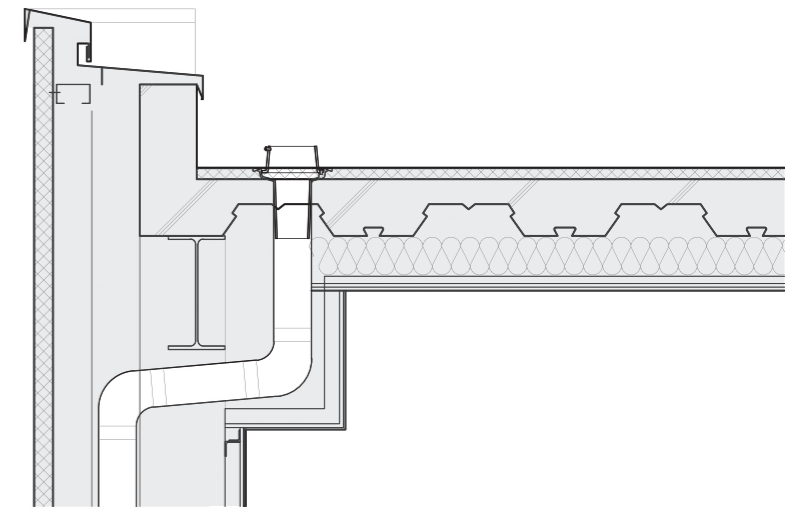
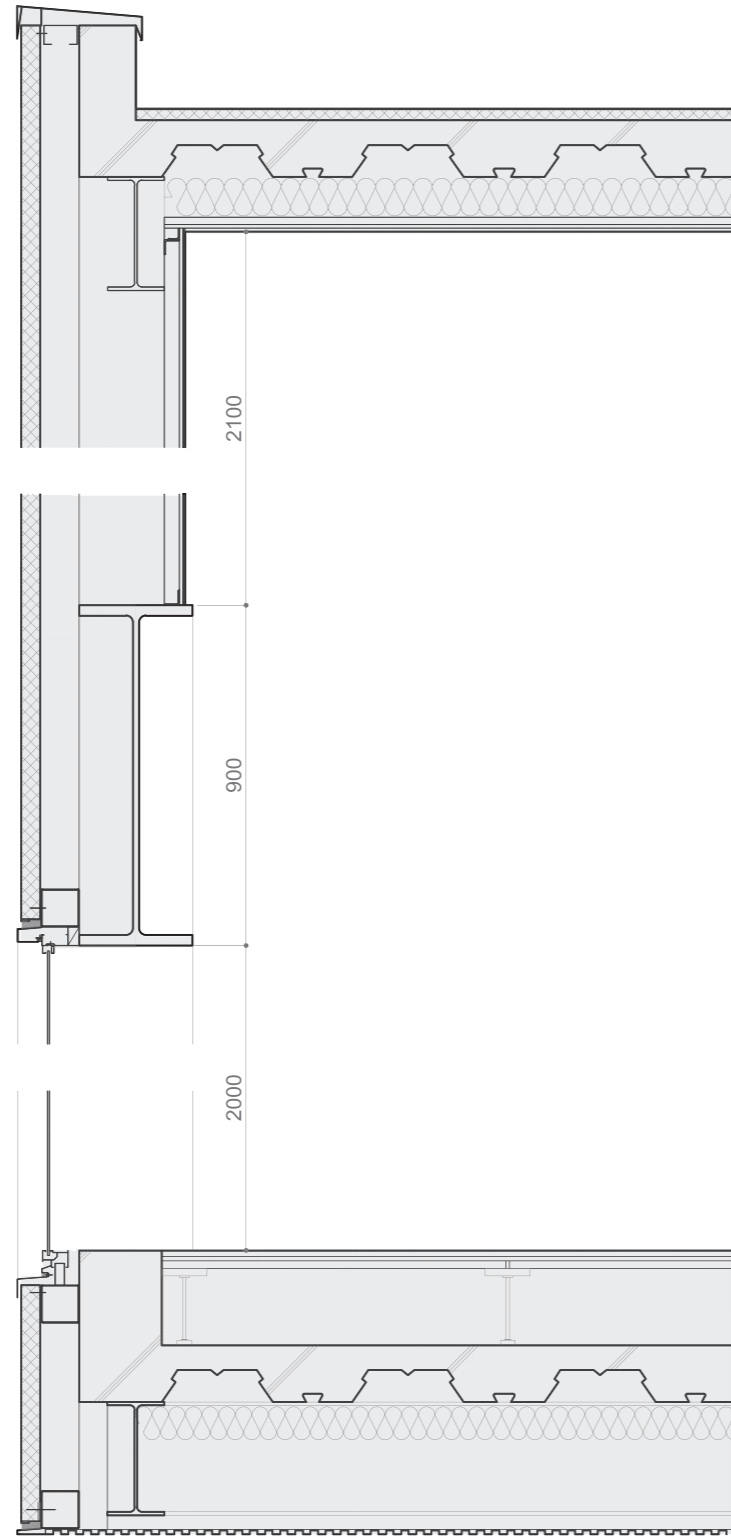

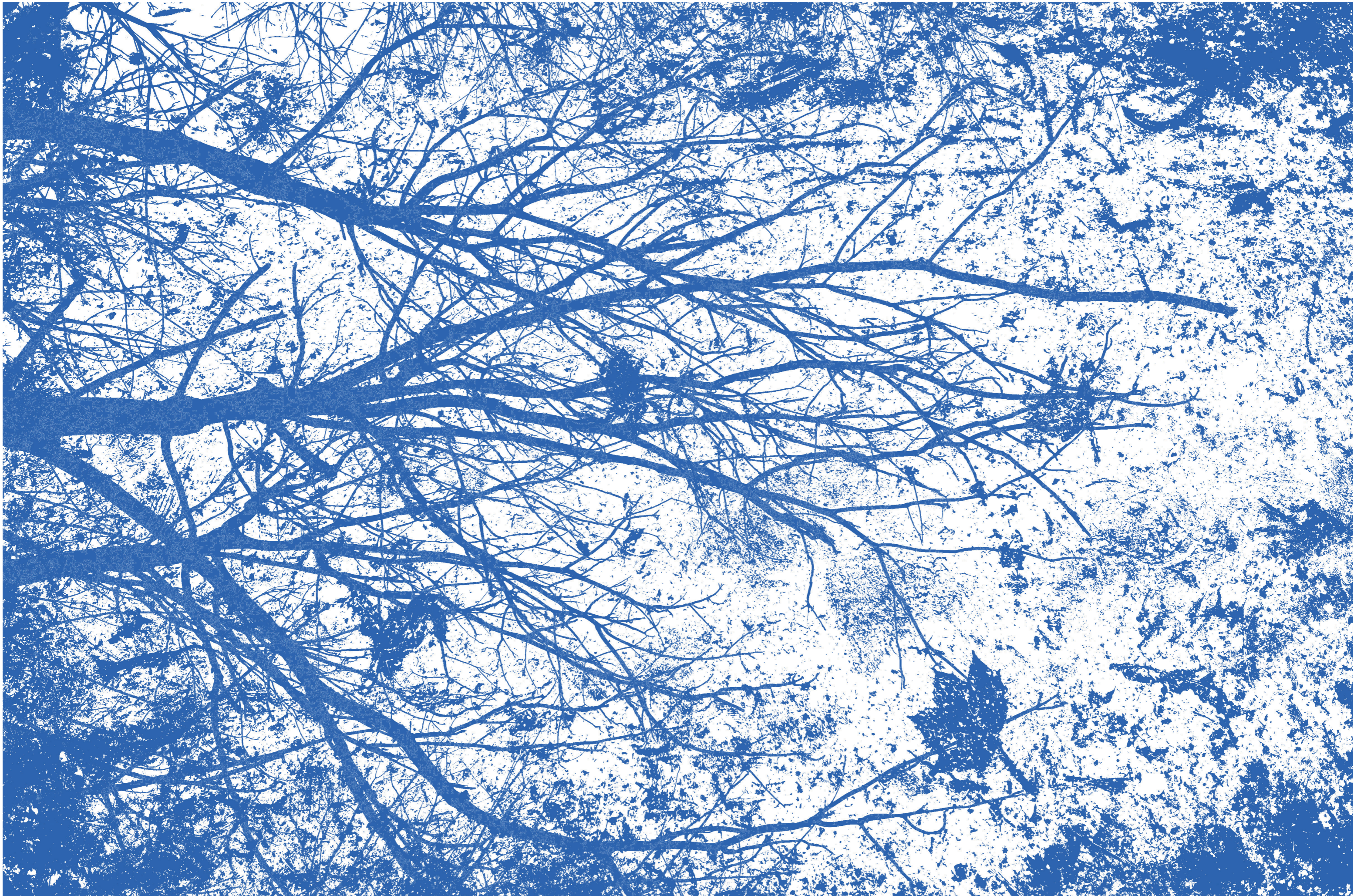

Merci beaucoup !!!!!!!!!!!!!